

Voltage Dimmed 28V LED Switch & Annunciator Order Sheet

Contact Information:

Company: _____ Contact: _____

Phone: _____ Fax: _____

**Fax to 214-320-1057
For Immediate Order Processing**

Date: _____

1 Part # to Order:

Choose one from below:

- 982561 ● — Indicator
- 982431 ● — MOM 2 Pole Switch
- 982441 ● — ALT 2 Pole Switch

2 LED Polarity: (Choose one from below)

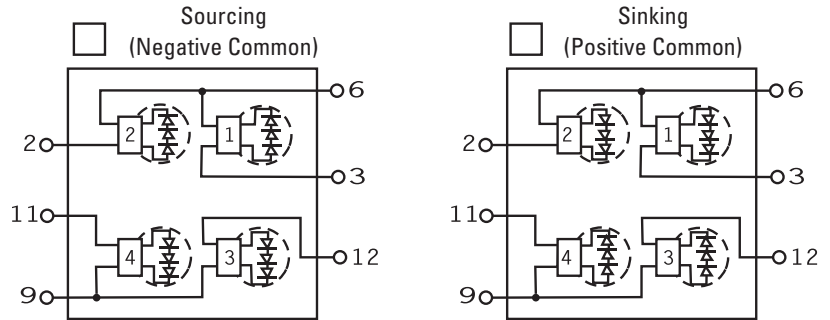

3 Display Configuration:

Choose one from below:

Or Draw a configuration: _____



4 Color Filter Selection:

- A. Draw the Display Configuration selected in Step 3 in the box supplied
- B. Now place the letter of the desired color in each segment. Use color guide supplied at right. (See our web site for color view)



Color Guide:

- A = Amber
- B = Blue
- G = Green
- R = Red
- W = White
- VW = **Visible White**

5 Custom Legend:

- A. Draw the Display Configuration selected in Step 3 in the box supplied
- B. Draw the desired text in each segment

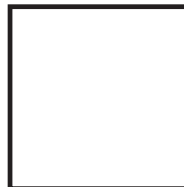

Notes:

6 Display Type:

_____ (Use table at right)

Description:

- White text lights in color when energized. ● — 1
- White background lights in color when energized. ● — 2
- Hidden text lights in color when energized. ● — 5
- Hidden background lights in color when energized. ● — 4
- Hidden background lights in color when energized, Text is white at all times (visible white). ● — 9
- Colored background lights in color when energized. ● — 6
- Top half: Visible white text lights in color when energized. ● — 12
- Bottom half: Hidden text lights in color when energized. ● — 36
- Top half: Hidden text lights in color when energized. ● — 36
- Bottom half: Visible white text lights in color when energized. ● — 36

Display Type

Display Type	Light Source Not Energized		Light Source Energized	
	Legend	Background	Legend	Background
1	white	black	color	black
2	black	white	black	color
5	black	black	color	black
4	black	black	black	color
9	white	black	white	color
6	black	color	black	color
12	white	black	color	black
36	black	black	color	black
36	black	black	color	black
36	white	black	color	black

US/Canada 800-527-2581
PH: 214-320-9770
email: dai@dallasavionics.com

PA 800-523-5949
Fax: 214-320-1057
www.dallasavionics.com

DALLAS AVIONICS, INC.