

## *RangePRO Model L5LUR* Laser Rangefinder Module

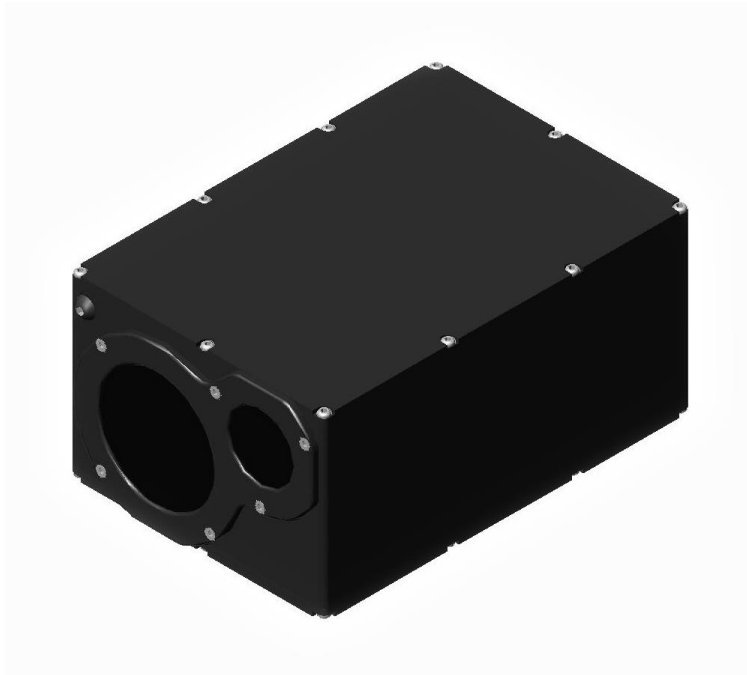

### TABLE OF CONTENTS

Chapter	Page
<b>1 DESCRIPTION</b>	<b>1-1</b>
<b>2 SPECIFICATIONS</b>	<b>2-1</b>
2.1 System Performance	2-1
2.2 Communications	2-2
2.3 Physical Characteristics	2-2
2.4 Electrical Requirements	2-3
2.5 Environmental	2-3
2.6 Connector/Pin Details	2-3
<b>3 SET-UP</b>	<b>3-1</b>
3.1 Mounts	3-1
3.2 Connections	3-1
<b>4 OUTLINE DRAWINGS</b>	<b>4-1</b>
<b>LIST OF FIGURES</b>	
Figure 3-1: Mounts	3-1
Figure 3-2: Connections	3-1
Figure 4-1: Outline Drawing	4-1

$$P_R = \frac{P_L \times Z^2 \times \delta \times D_L^2 \times A_L \times \cos\beta}{4 \times R^2 \times A_L}$$

## *RangePRO Model L5LUR* Laser Rangefinder Module

### 1 DESCRIPTION

The RangePRO Model L5LUR is an OEM laser rangefinder module providing an advanced digital rangefinding capability for military, paramilitary and commercial applications. It may be operated as a single shot rangefinding device, or at ranging rates up to 1Hz.

It integrates with host systems such as weapon, sensing, or surveillance and tracking stations, and thermal imaging cameras. It requires power and control command input, and provides range-to-target and self-diagnostic data output.

The L5LUR ranges at low repetition rates over distances to 10km depending on target size, target reflectivity, atmospheric conditions and customer supplied external optics (typically greater than 5km for vehicle type targets).

The transmitter is a collimated eye-safe laser system. It can provide ranging rates from single shot up to 40 per minute.

The unit is fully sealed, purged and backfilled with dry air.

Advanced digital signal processing techniques are employed to provide accurate, reliable ranging. Signals from the detector are digitally sampled. The samples are examined to determine all potential real target returns. If a valid target is detected within the user-set range gate it's range data is output, if more than one target is detected within the range gate the nearest or farthest may be selected for data output.

All signal and range computation is done "on the fly". Using this philosophy, the only task remaining after the sampling has expired is to transfer the range data through the serial port. Effectively the speed of the signal processing is limited only by the data output rate.

The system employs an adaptive range threshold to compensate for changing noise levels. The worst case for noise is when the system electronics are being operated at the high end of their temperature specification and when ranging is being performed in strong sunlight. The best case is the reverse situation. The adaptive range threshold feature results in more reliable ranging (fewer false alarms) when noise is elevated and higher sensitivity (further ranging) when noise is reduced, thus maximising the system capability under varying conditions. The threshold is calculated on a "shot-by-shot" basis.

RangePRO laser rangefinder software is easily upgradeable, upgrades can be downloaded in the field via a PC.

$$P_R = \frac{P_L \times Z^2 \times \delta \times D_L^2 \times A_T \times \cos\beta}{4 \times R^2 \times A_L}$$

## RangePRO Model L5LUR Laser Rangefinder Module

### 2 SYSTEM SPECIFICATIONS

Notation - use of brackets in tables: [notes & qualifications] (units) {alternate units}.

#### 2.1 System Performance

PARAMETER		SPECIFICATION
<b>Control</b>		
<b>Control Functions</b>		all control functions and range data via comms port
<b>Ranging</b>		
<b>Laser Type</b>		Nd:YAG/OPO
<b>Wavelength (nm)</b>		1,565 to 1,575 [1,570 nominal]
<b>Output Energy [per pulse] (mJ)</b>		nominally 8 [up to max. allowable for Class 1M]
<b>Beam Diameter [at exit] (mm)</b>		20
<b>Beam Divergence [full angle; typical] (µrad)</b>		800
<b>Receiver Aperture (mm)</b>		42
<b>Detector</b>		InGaAs with time variant gain
<b>Range Read-out Limits (m)</b>	<b>minimum</b>	50
<b>[factory selectable]</b>	<b>maximum</b>	20,000
<b>Ranging Performance<sup>1</sup></b>	<b>vehicle [2.3x2.3m]</b>	> 6,000
<b>[Std. Clear<sup>2</sup>; max.] (m)</b>	<b>building [8x8m]</b>	> 9,000
<b>Range Accuracy [typical] (m)</b>		± 2 [4 rms over 10 shots]
<b>Target Discrimination (m)</b>	<b>Lateral [1m<sup>2</sup> targets @ 5,000m]</b>	≤ 25
	<b>Axial [between 100 &amp; 5,000m]</b>	≤ 100
<b>Ranging Rate [max.]</b>	<b>single shot (per minute)</b>	10 [continuously]
	<b>burst mode (Hz)</b>	1 <sup>3</sup>
<b>Safety &amp; Protection</b>		
<b>Laser Classification<sup>4</sup></b>		Class 1M
<b>Visible Emission Filter</b>		blocking
<b>Visible Emission [@ ≥ 5m]</b>		nil
<b>Audible Emission [@ ≥ 5m]</b>		nil

<sup>1</sup> Target albedo 0.05 @ 1,570nm.

<sup>2</sup> Standard Clear atmosphere; Extinction Coefficient 0.097 @ 1,570nm (RCA Handbook); sea level visibility = 23.5km.

<sup>3</sup> Continuous operation at 1Hz requires appropriate thermal mounting by the integrator. Otherwise operation is at 1Hz at a max. 70% duty cycle, e.g. max. 20s at 1Hz and 9s off. (Refer to manufacturer for modes of operation particular applications.)

<sup>4</sup> Australian/NewZealand Standard AS/NZS 2211.1:1997 *Laser Safety Part 1: Equipment classification, requirements and user's guide.*

## *RangePRO Model L5LUR* Laser Rangefinder Module

PARAMETER	SPECIFICATION
<b>Support</b>	
MTBF [ground mobile] (shots)	> 10 <sup>6</sup>
Operational Life (years)	10

### 2.2 Communications

PARAMETER	SPECIFICATION
Port(s)	one serial port [shared with power input]
Type	RS-422
Data Rate	19,200

### 2.3 Physical Characteristics

PARAMETER	SPECIFICATION	
Mass [approx.] (g)	1,050	
Dimensions [approx.] (mm) <sup>5</sup>	Length (inc. windows)	138
	Length (body only)	135.5
	Width	94
	Height	66
Specific Gravity	> 1 [non-floatation]	
Mounting	3-point mount, tapped M4 holes, 5mm deep; 2x 3mm dia. reference pins	

### 2.4 Electrical Requirements

PARAMETER	SPECIFICATION	
Supply Voltage [external] (Vdc)	10 to 32	
Power Consumption (W)	typical [standby]	< 1
	peak [while charging]	< 12

<sup>5</sup> Excluding connectors, mounting feet and external windows.

$$P_R = \frac{P_L \times Z^2 \times \delta \times D_L^2 \times A_1 \times \cos\beta}{4 \times R^2 \times A_L}$$

## *RangePRO Model L5LUR* Laser Rangefinder Module

### 2.5 Environmental

PARAMETER			SPECIFICATION
Temperature (°C)	Operate	min. <sup>6,7</sup>	-20
		max. <sup>8</sup>	+50
	Survive	min. <sup>7</sup>	-46
		max. <sup>8</sup>	+71
Vibration and Shock <sup>9</sup>			MIL-STD-810F, ground mobile
Sealing <sup>10</sup>			immersion proof
EMI/EMC <sup>9,10</sup>			MIL-STD-461D

### 2.6 Connector/Pin Details

PARAMETER		SPECIFICATION
<b>Power Input &amp; Comms Port Connection:</b> Connector, MilSpec, Panel, Plug, Bayonet, 8 Way, 12 Shell, Pattern 105, square flange, Mil-C26482, AB05 2100 12-8P N00		
<b>Purpose</b>		dc power input and RS-422 Serial Comms
<b>Pins</b>	<b>A</b>	+V, dc power in
	<b>B</b>	TX-
	<b>C</b>	TX+
	<b>D</b>	RX+
	<b>E</b>	RX-
	<b>F</b>	GND POWER
	<b>G</b>	GND CHASSIS
	<b>H</b>	RS-422 COMMON

<sup>6</sup> Without wind chill.

<sup>7</sup> Can operate at lower temperatures with some degradation of range performance.

<sup>8</sup> Without solar radiation.

<sup>9</sup> Refer to manufacturer for details.

<sup>10</sup> With compliant line connectors attached.

$$P_R = \frac{P_L \times Z^2 \times \delta \times D_L^2 \times A_1 \times \cos\beta}{4 \times R^2 \times A_L}$$

## *RangePRO Model L5LUR* Laser Rangefinder Module

### 3 SET-UP

#### 3.1 Mounts

The RangePRO mounting arrangement is located on the bottom face:  
three tapped M4 holes, 5mm deep; and  
two stainless steel 3mm dia. dowel guide pins, 3mm long.

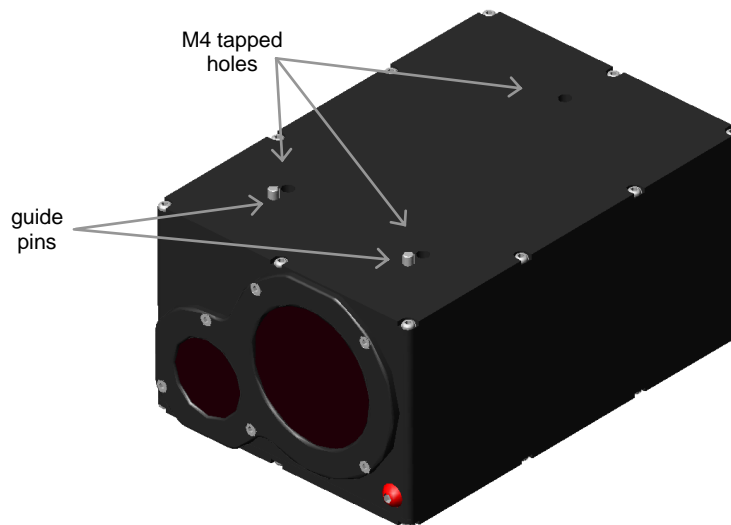

Figure 3-1: Mounts

#### 3.2 Connections

**CAUTION:** do not connect or disconnect when external power is applied;  
user-supplied connections must be correctly wired (see Connector/Pin Details).

The RangePRO has one connection point, being an 8 Way MilSpec panel plug, located on the rear of the unit. Refer to specifications for connection details.

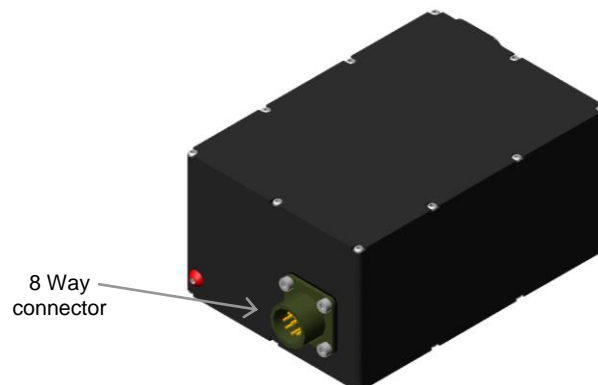

Figure 3-2: Connections

# Product Specification



## RangePRO Model L5LUR Laser Rangefinder Module

### 4 OUTLINE DRAWING

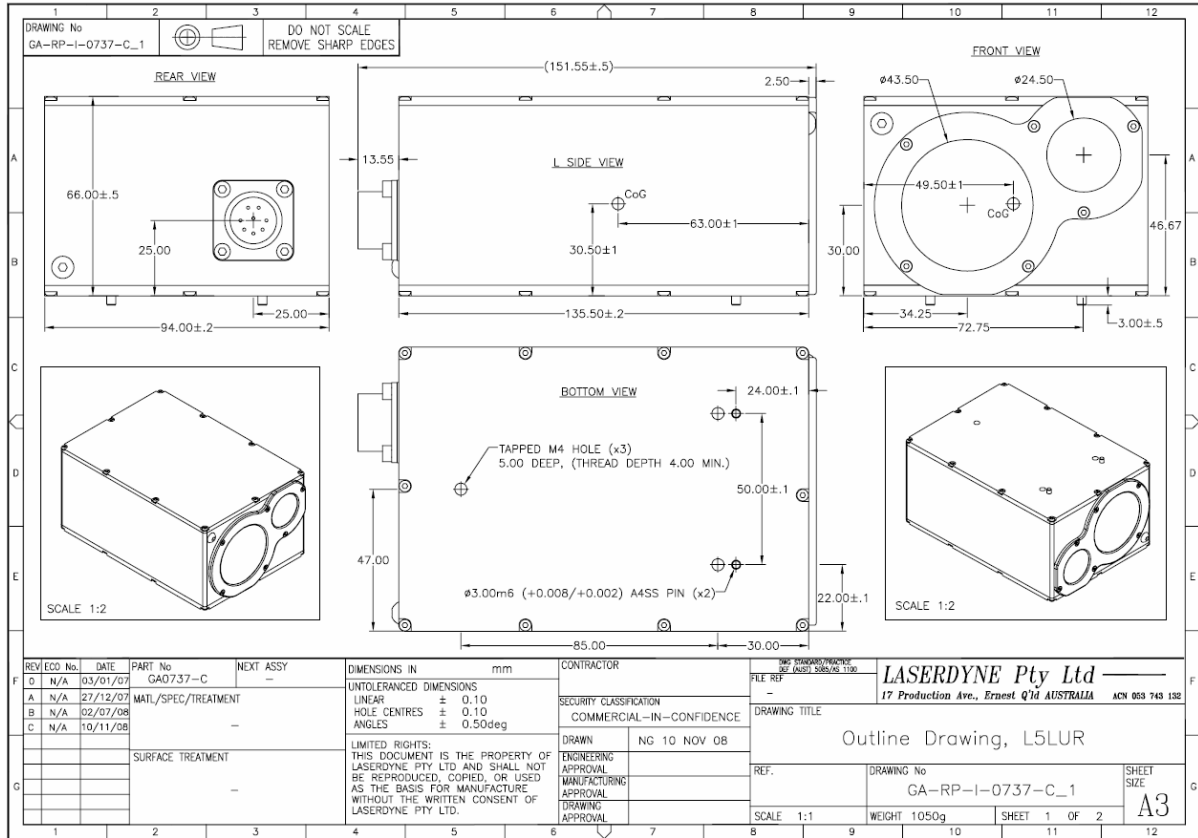

Figure 4-1: Outline Drawing



A Division of Laserdyne Pty Ltd  
A.C.N. 053 743 132

P.O. Box 6541 17 Production Ave  
GCMC Bundall Molendinar  
Queensland 9726 Queensland 4214  
Australia Australia

Tel: (07) 5594 9772 Int'l Tel: 61 7 5594 9772  
Fax: (07) 5594 9981 Int'l Fax: 61 7 5594 9981

email: laserdyne@laserdyne.com.au  
website: www.laserdyne.com.au

The information contained herein is proprietary to Laserdyne Pty Ltd. No part of this work may be reproduced or copied in any way without prior written permission of Laserdyne Pty Ltd.  
Note: specifications herein are subject to change without notice.

Copyright. All Rights Reserved. Laserdyne Pty Ltd

File: PS-RP-S-1092-A_1	Author(s): TW	Authorised: TW	Rev. Date: 25.3.14	Page 4-1
------------------------	---------------	----------------	--------------------	----------