

## Installation Manual and Operating Instructions

### TA202 Series High Power USB Charging Port



**True Blue Power®** is a division of Mid-Continent Instrument Co., Inc.

Mid-Continent Instrument Co., Inc.  
dba Mid-Continent Instruments and Avionics  
9400 E. 34<sup>th</sup> Street N.  
Wichita, KS 67226  
PH (800) 821-1212 FX (316) 630-0723

Manual number 9017899  
Revision E, January 4, 2017

## FOREWORD

This manual provides information intended for use by persons who, in accordance with current regulatory requirements, are qualified to install this equipment. If further information is required, please contact:

True Blue Power  
c/o Mid-Continent Instrument Co., Inc.  
Attn: Customer Service Dept.  
9400 E. 34th Street N.  
Wichita, KS 67226 USA  
PH (316) 630-0101  
FX (316) 630-0723  
[www.truebluepowerusa.com](http://www.truebluepowerusa.com)  
[www.mcico.com](http://www.mcico.com)

We welcome your comments concerning this manual. Although every effort has been made to keep it free of errors, some may occur. When reporting a specific problem, please describe it briefly and include the manual part number, the paragraph/figure/table reference and the page number. Send your comments to:

True Blue Power  
c/o Mid-Continent Instrument Co., Inc.  
Attn: Technical Publications  
9400 E. 34th Street N.  
Wichita, KS 67226 USA  
PH (316) 630-0101  
FX (316) 630-0723

All products produced by Mid-Continent Instrument, Co., Inc., including those identified as Mid-Continent Instruments and Avionics or True Blue Power, are designed and manufactured in Wichita, KS, USA.

© Copyright 2017  
Mid-Continent Instrument Co., Inc.

## REVISION HISTORY

<b>Rev.</b>	<b>Date</b>	<b>Approved</b>	<b>Detail</b>
A	03/14/16	BAW	Initial release.
B	04/25/16	CAS	Updated formatting, added AEH statement to table 1.3
C	05/10/16	BAW	Added single port unit mounting options, removed configurations table.
D	06/23/16	ScH	Added two screws (1/4") to included connector kit.
E	01/04/17	BAW	Updated to include new mounting option. Added 1.2.4.

## **TABLE OF CONTENTS**

### **SECTION 1 GENERAL DESCRIPTION**

- 1.1 INTRODUCTION
- 1.2 TECHNICAL SPECIFICATIONS
  - 1.2.1 ELECTRICAL ATTRIBUTES
  - 1.2.2 PHYSICAL ATTRIBUTES
  - 1.2.3 QUALIFICATIONS
  - 1.2.4 CONFIGURATIONS

### **SECTION 2 PRE-INSTALLATION CONSIDERATIONS**

- 2.1 COOLING
- 2.2 EQUIPMENT LOCATION
- 2.3 ROUTING OF CABLES
- 2.4 LIMITATIONS
- 2.5 MODIFICATIONS

### **SECTION 3 INSTALLATION PROCEDURES**

- 3.1 GENERAL INFORMATION
- 3.2 UNPACKING AND INSPECTING
- 3.3 CABLE HARNESS
  - 3.3.1 WIRE GAUGE SELECTION
  - 3.3.2 PIN ASSIGNMENT INFORMATION
  - 3.3.3 HARNESS VERIFICATION
- 3.4 MOUNTING
- 3.5 INSTALLATION COMPLETION

### **SECTION 4 OPERATION**

- 4.1 ELECTRICAL PERFORMANCE
- 4.2 PROTECTIVE FEATURES
  - 4.2.1 SHORT CIRCUIT PROTECTION
  - 4.2.2 OVER-CURRENT PROTECTION
  - 4.2.3 LOW INPUT VOLTAGE SHUTDOWN
  - 4.2.4 OVER-TEMPERATURE

### **SECTION 5 CONFORMANCE**

- 5.1 CONTINUED AIRWORTHINESS STATEMENT
- 5.2 ENVIRONMENTAL QUALIFICATION STATEMENT

## SECTION 1 GENERAL DESCRIPTION

### 1.1 INTRODUCTION

The TA202 Series High Power USB Charging Port is a certified accessory that converts 10 to 32 volts of DC electrical input from the aircraft to standard 5 volt power for any electronic product that charges using a USB connector. The TA202 provides one or two Universal Serial Bus-A or C (USB-A or USB-C) ports and can be rear mounted or front mounted in a variety of locations throughout the aircraft. The new “Type-C” USB port design is a smaller port that accommodates the latest consumer electronic devices on the market. Among other features, the Type-C connector accepts reversible cable plugging with no ‘up’ or ‘down’ requirement for cable orientation. The unit is certified to FAA TSO C71 and qualified to multiple RTCA DO-160 requirements, providing confidence and allowing installation in the cockpit or cabin.

This High Power USB Charging Port is designed as a DCP (Dedicated Charging Port) to industry-standard protocol per the *USB Battery Charging 1.2 Compliance Plan*. It also complies with the higher power requirements of *USB Power Delivery 2.0*. Newer electronics, such as the Apple iPad®, other tablets and larger devices can accept or may require 2.1 amps or more to charge and operate. As a high power DCP, the TA202 can provide up to 3.0 amps of power to charge USB devices, including the higher demand products. Most dual USB chargers typically provide 1.0 amp on one port and 2.1 amps on the second port, but the TA202 can provide 3.0 amps to both ports simultaneously (for dual port units). The unit has built-in protections for short circuit, over-current, and low voltage conditions. It is designed to protect against reverse polarity installation and has temperature monitoring and shutdown capability, allowing the unit to handle unforeseen conditions safely.

Small, compact and powerful, with plenty of installation flexibility, the TA202 is an ideal choice as a highly useful and effective addition to any aircraft.

## 1.2 TECHNICAL SPECIFICATIONS

### 1.2.1 Electrical Attributes

Input Voltage:	10-32 VDC
Input Power:	35 watts max; 2.5 amps @ 14 VDC / 1.25 amps @ 28 VDC
Output Voltage:	5 VDC ±0.25 per port
Output Power:	3.0 amps max per port
Efficiency:	~90% nominal

**Table 1.1**

### 1.2.2 Physical Attributes

Weight:	1.3 oz. (38 g) (dual port), 0.8 oz. (23 g) (single port)
Dimensions (Dual Port Units): (not including connector)	1.50 inches wide X 1.03 inches high X 1.25 inches deep
Dimensions (Single Port Units): (not including connector)	1.50 inches wide X 0.52 inches high X 1.25 inches deep
Charging Ports Type:	USB Standard-A or USB Standard-C
Connector Kit:	MCIA P/N 9017960
Mounting:	Panel mount; rear or front

**Table 1.2**

### 1.2.3 Qualifications

Certification:	FAA TSO-C71
	EASA ETSO-C71
Environmental Qualification:	RTCA DO-160G Environmental Category F1S2BB[(RCC1)(UG)]XXXXXXY[B(XX)]BRXXMXXXAX
Airborne Electronic Hardware:	RTCA DO-254, Design Assurance Level E

**Table 1.3**

### 1.2.4 Versions

	Non Lighted	Lighted	Power Input Location	USB Connector
<b>Part Numbers</b>	6430202-1	6430202-11	Rear	Dual: Type A+Type C
	6430202-2	6430202-12	Bottom	
	6430202-3	6430202-13	Rear	Dual: Type C+Type C
	6430202-4	6430202-14	Bottom	
	6430202-5	6430202-15	Rear	Dual: Type A+Type A
	6430202-6	6430202-16	Bottom	
	6430202-7	6430202-17	Rear	Single: Type C
	6430202-8	6430202-18	Bottom	
	6430202-9	6430202-19	Rear	Single: Type A
	6430202-10	6430202-20	Bottom	

**Table 1.4**

## **SECTION 2 PRE-INSTALLATION CONSIDERATIONS**

### **2.1 COOLING**

No external cooling is required. The unit will become warm when in use. This is normal and within operational parameters. No special mounting considerations are required; however, mounting to a metal surface can help dissipate any heat generated and extend the life of the product.

### **2.2 EQUIPMENT LOCATION**

The TA202 High Power USB Charging Port is designed for mounting flexibility, allowing for installation in the cockpit or in the cabin. It is designed for panel mounting and can be installed in a rectangular configuration or, with an available installation kit, can be front mounted with a cosmetic cover plate. An instrument mounting adapter bracket is also available to easily mount the unit in a standard 2-inch round instrument opening that may already exist in the cockpit panel. There are two versions to choose from which allow the input connector to be located either on the rear of the unit or from the bottom.

The unit can be mounted in any orientation. Clearance should be provided for the mating connector which may require an additional inch beyond the rear of the unit.

### **2.3 ROUTING OF CABLES**

Avoid sharp bends in cabling and routing near aircraft control cables. Avoid close proximity and contact with aircraft structures, avionics equipment or other obstructions that could chafe wires during flight and cause undesirable effects.

### **2.4 LIMITATIONS**

Environmental qualifications were verified per RTCA DO-160, Revision G in lieu of those identified within the minimum performance standards (MPS) of the TSO.

The conditions and tests for TSO approval of this article are minimum performance standards. Those installing this article, on or in a specific type or class of aircraft, must determine that the aircraft installation conditions are within the TSO standards, specification of the article and deviations as listed above. TSO articles must have separate approval for installation in an aircraft. The article may be installed only according to 14 CFR part 43 or the applicable airworthiness requirements.

The USB Type-C interface is an exciting new connector for electronic devices. Beyond the physical format of the Type-C connector, it also allows for a variety of interface options when communicating with compatible devices. This device-to-charger communication is defined within the USB 3.1 Specification and Power Delivery 2.0 standards. However, manufacturers of consumer electronic devices and/or cables may choose to implement proprietary versions or modifications of the USB standards to operate specifically with their own charging equipment. The TA202 has been tested with and supports a wide variety of devices now emerging on the open market. However, compatibility with all devices may not be guaranteed. True Blue Power continues to be proactive in evaluating new devices and strives to continually improve the product as needed to serve the vast majority of USB Type-C electronic products.

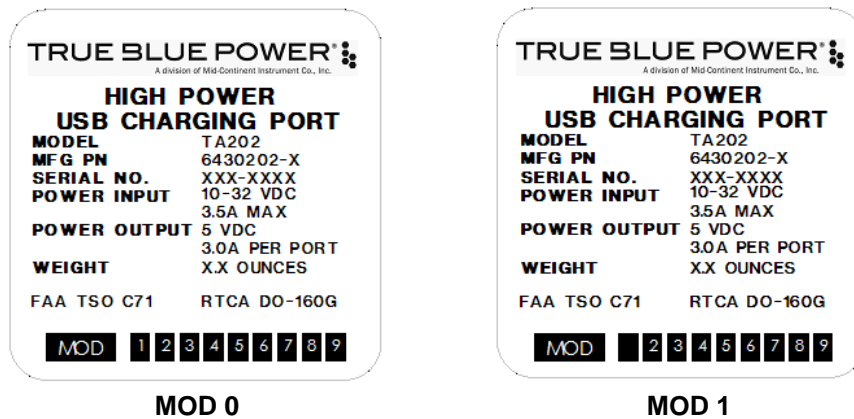
## 2.5 MODIFICATIONS

Each TA202 series High Power USB Charging Port (part number 6430202-( )) has a nameplate that identifies the manufacturer, model, part number, description, certifications and technical specifications of the unit. The nameplate also includes the “MOD” or modification status representing notable changes in the design of the unit. The following identifies each “MOD” or modification.

Modification (MOD) 0 is the initial release of the TA202 series High Power USB Charging Port and is identified on the nameplate by the lack of marking on the MOD numbers 1 through 9 (i.e. 1-9 are visible).

All subsequent modifications are identified on the nameplate by the marking/blacking out of that particular MOD number (i.e. for MOD 1, the number 1 is not visible and 2-9 are visible). See Figure 2.1 for examples.

For additional details regarding design changes to the TA202 series High Power USB Charging Port, refer to individual Service Bulletins associated with each MOD.



**Figure 2.1  
Nameplate and MOD Status Examples**



## SECTION 3 INSTALLATION PROCEDURES

### 3.1 GENERAL INFORMATION

This section contains interconnect diagrams, mounting dimensions and other information pertaining to the installation of the TA202 Single and Dual USB Charger. After installation of cabling and before installation of the equipment, ensure that power and ground are applied to the proper pins specified in Section 3.3.2, Pin Assignment Information.

### 3.2 UNPACKING AND INSPECTING EQUIPMENT

When unpacking this equipment, make a visual inspection for evidence of any damage that may have occurred during shipment. The following parts should be included:

- |  |                      |
|--|----------------------|
| a. High Power USB Charging Port        | MCIA P/N 6430202-( ) |
| b. Installation Manual                 | MCIA P/N 9017899     |
| c. Connector Kit                       | MCIA P/N 9017960     |
| i. Mating Connector, 2-pin             |                      |
| ii. Pins (4) (2 required, 2 spares)    |                      |
| iii. Screws, #4-40 x 1/4 flat-head (2) |                      |
| iv. Screws, #4-40 x 5/16 flat-head (2) |                      |

Optional Equipment Available:

- |                                 |                  |
|---------------------------------|------------------|
| a. Front Mount Installation Kit | MCIA P/N 9017897 |
| b. Instrument Mount Adapter Kit | MCIA P/N 9017947 |
| c. Rear Mount Installation Kit  | MCIA P/N 9017958 |

Equipment Not Provided:

- |  |  |
|--|--|
| a. Cable Harness Wire  | See Section 3.3.1 for specifications             |
| b. Circuit Breaker Recommendation<br>(as needed per system requirements) | 3 amp (2 amp may be sufficient for 28V aircraft) |

### 3.3 CABLE HARNESS

Construct the cable harness following the instructions outlined below and per Figure 3.1. Refer to Section 2: Pre-Installation Considerations, for routing precautions.

#### 3.3.1 Wire Gauge Selection

Use of PTFE, ETFE, TFE, Teflon or Tefzel insulated wire is recommended for aircraft use. The wire harness should utilize 20-24 AWG stranded wire. Refer to table 3.1 below.

Wire Gauge	Wire Length
20 AWG stranded wire	35 ft
22 AWG stranded wire	22 ft
24 AWG stranded wire	14 ft

**Table 3.1  
Wire Gauge and Length**

Note: Pins should be crimped using Molex Hand Crimp Tool 63819-0000 (Preferred), 63811-2800 (obsolete) or 11-01-0200 (obsolete). See the Molex Hand Crimp Tool User Manual for crimp procedures.

### 3.3.2 Pin Assignment Information

#### INPUT POWER:

**Pin A** (keyed) – Positive DC input +10 to 32 VDC power

**Pin B** – Negative DC input / ground

### 3.3.3 Harness Verification

#### Note:

The TA202 has built-in reverse polarity protection for the power connector. If Pins A and B are swapped, the unit will not be damaged, but will also not function.

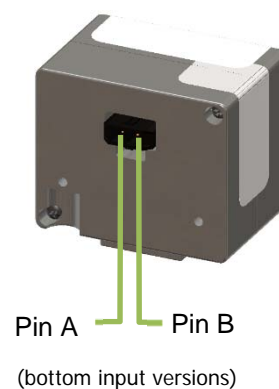
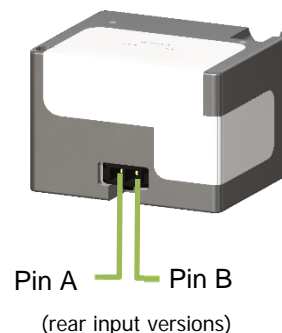
Once the cable harness is prepared, prior to connecting the TA202, activate the aircraft power bus and use a multimeter to verify that aircraft power and ground is supplied with appropriate voltage on the proper pins within the mating harness.

## 3.4 MOUNTING

The TA202 can be installed in one of four ways:

- rear mount, rectangular
- instrument mount \*
- front mount, decorative bezel\*
- rear mount, decorative bezel\*

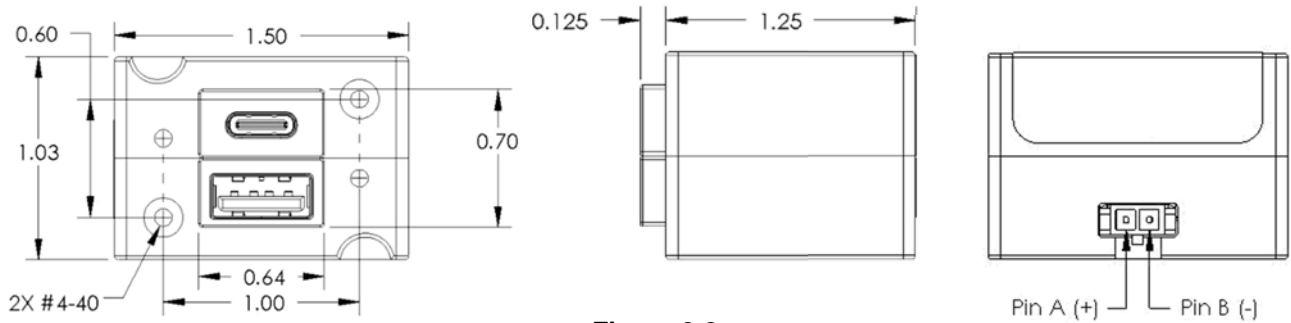
\* Installation kit required, dual port units only. See Section 3.2, Optional Equipment Available for part number reference



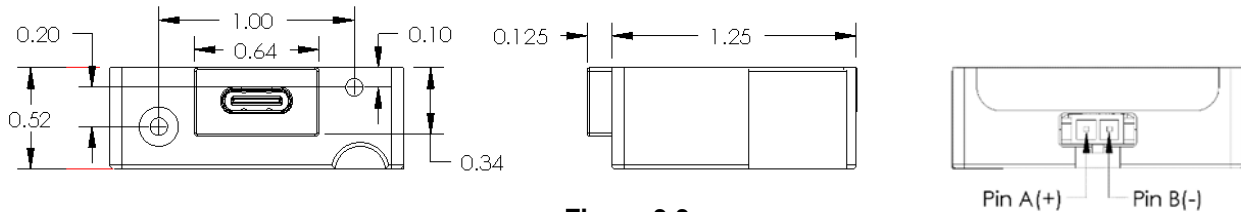
**Figure 3.1**  
**Power Input**

Prepare the panel cutout as shown in Figures 3.3, 3.4, or 3.5 per the selected mounting option.

- For Rear Mount (rectangular) and Instrument Mount Installations countersinks in the panel for flat head screws are optional. However, flat head screws are provided for flush appearance. For Front and Rear Decorative Bezel Installations, countersinks in the panel are required.
- For Rear Mount Installations:  
Mounting screws length MUST be between (PT +0.150") and (PT +0.210"). [PT = panel thickness]  
Mounting screws provided with the unit are 0.24" and 0.31". (accommodates 0.030" to 0.160" PT)  
For PT greater than 0.125, the USB connector will be below the surface of the panel (below flush).
- For Front Mount Installations: Minimum panel thickness is 0.04". Maximum panel thickness is 0.20".
- For Rear Mount Installation with Decorative Bezel: Panel thickness greater than 0.065 will cause the USB connector to be below the surface of the bezel (below flush).



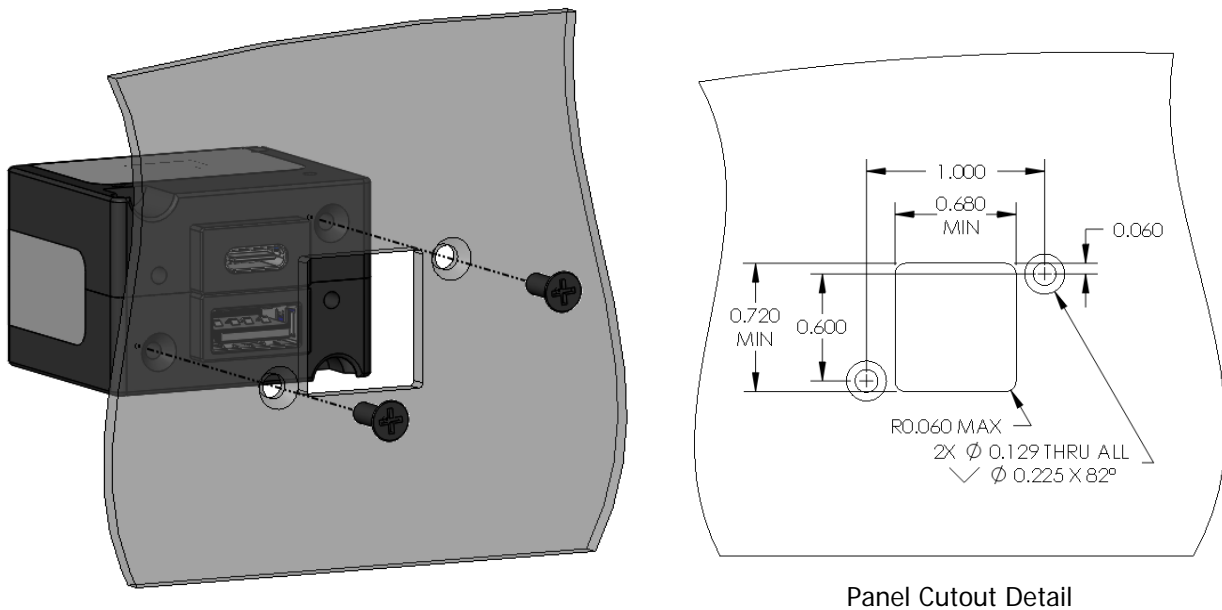
**Figure 3.2**  
**TA202 Outline Drawing**  
(dual port, rear input version shown)



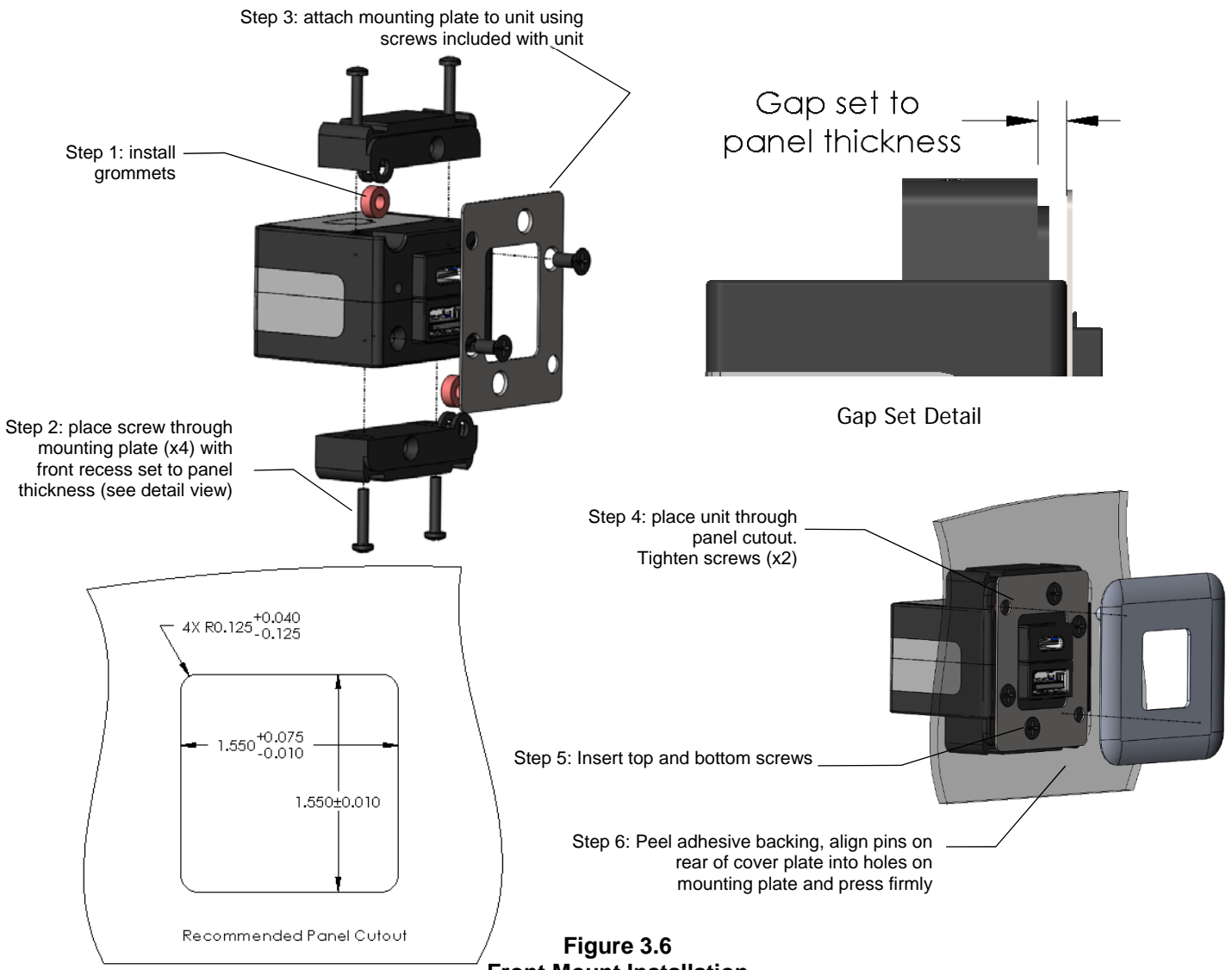
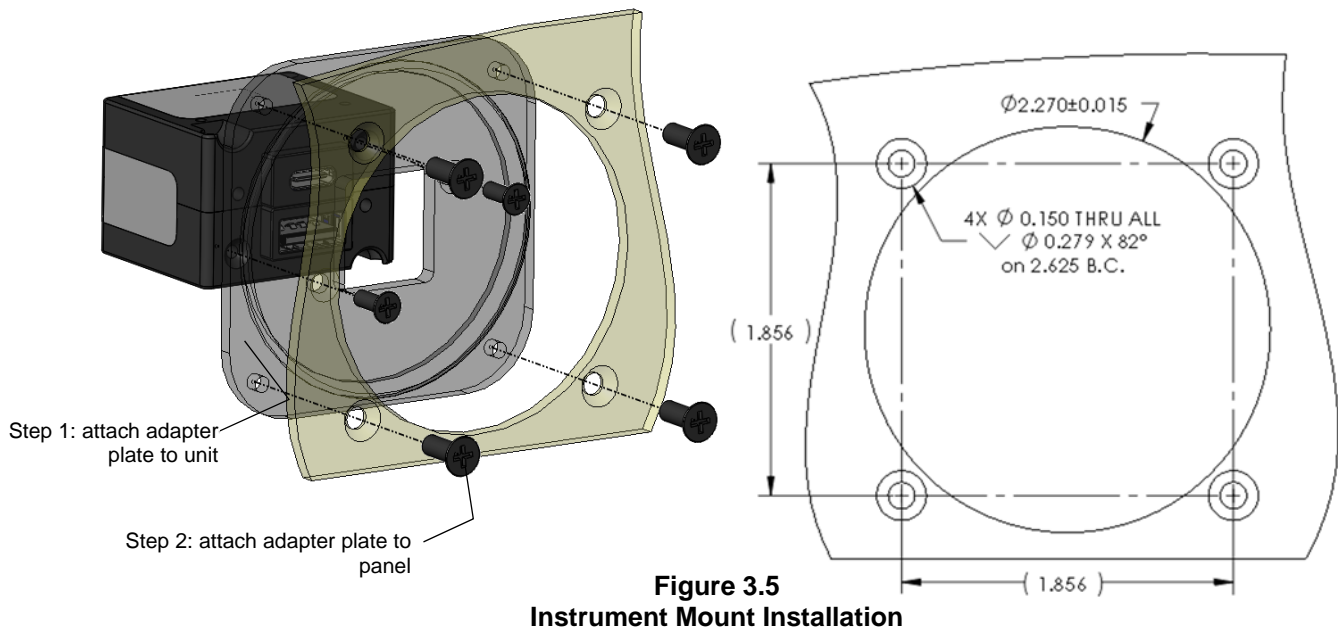
**Figure 3.3**  
**TA202 Outline Drawing**  
(single port, rear input version shown)

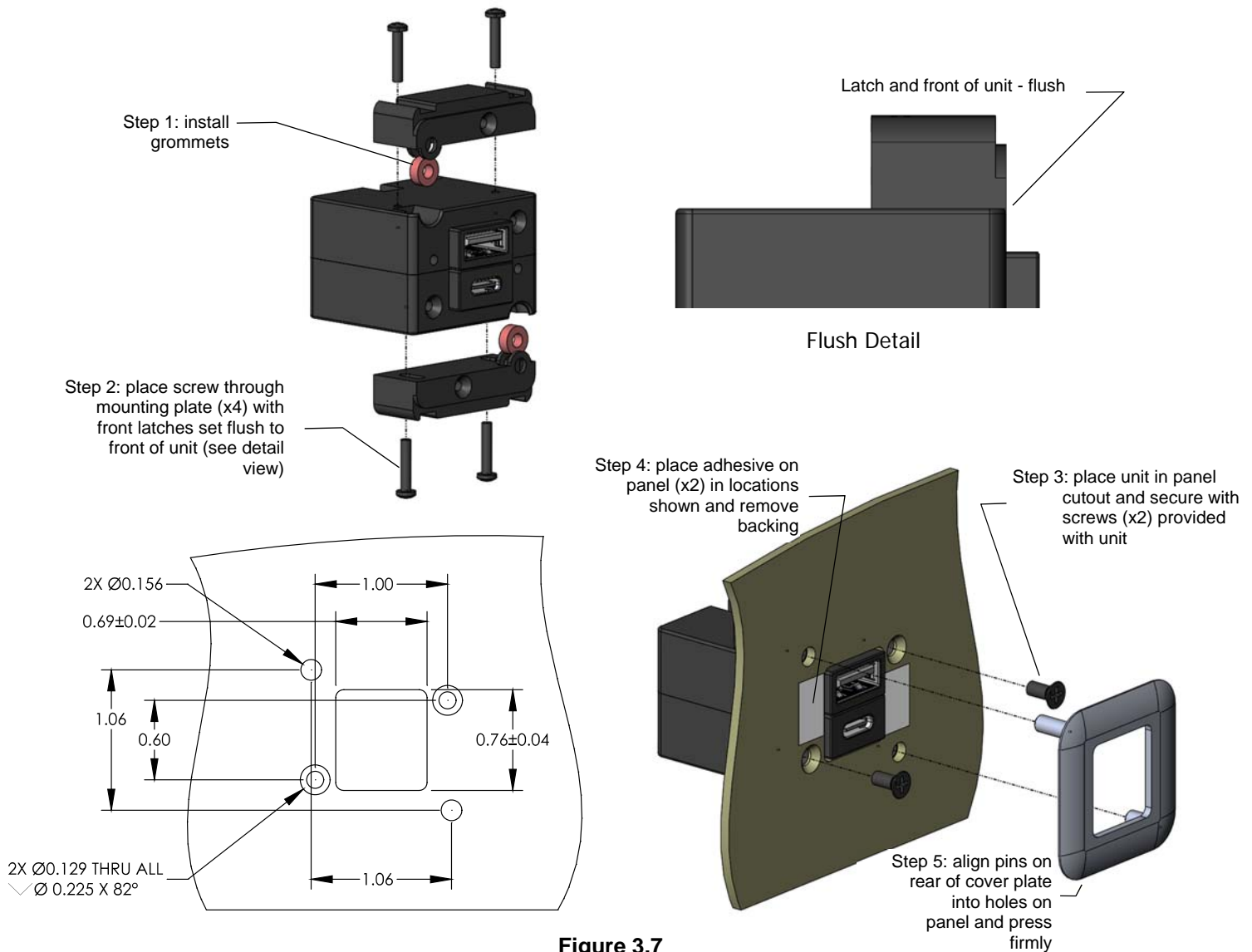
### 3.5 INSTALLATION COMPLETION

Prior to operating the unit in the aircraft, it is recommended to verify the output and functionality of the unit. In order to prevent accidental damage to other systems, it is not recommended to attach the output to other equipment prior to verification. Verify the output of the unit at the terminating end of the cable with a multimeter to ensure proper voltage and polarity. Once verified, installation can be completed and functionality should be checked.

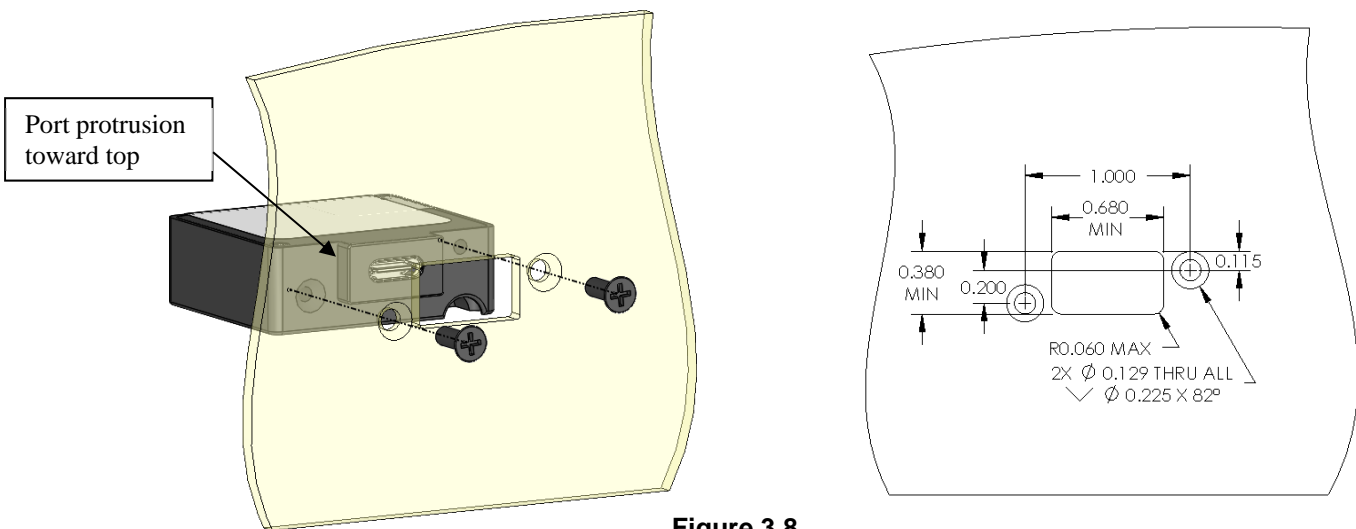


**Figure 3.4**  
**Rear Mount Installation**





**Figure 3.7**  
**Rear Mount Installation with Cover Plate**



**Figure 3.8**  
**Single Port Rear Mount Installation**

## SECTION 4 OPERATION

### 4.1 ELECTRICAL PERFORMANCE

The TA202 Series High Power USB Charging Port converts an aircraft (DC) input voltage within the range specified to a 5V (DC) output. This output power is applied to a single or dual USB-A or USB-C connector in accordance with the *USB Implementers Forum*.

The USB D+ and D- data lines communicate with the USB portable device to tell the device it is a dedicated charging port (DCP), capable of a higher current than a standard USB port. This allows the USB portable device to draw up to 3.0 Amps.

The unit is designed as a DC-to-DC converter with a series switch on each output to regulate current applied to that output. Each series switch independently reduces the output current to a safe level if the USB portable device draws excess current, is shorted or has a fault.

If the temperature of the TA202 becomes elevated due to a fault or excessive load, the device will seamlessly communicate with the USB portable device to lower the charge current. This allows the device to continue charging while the unit returns to a temperature within designed limits. When the temperature returns to a safe level the TA202 will automatically reestablish the higher charge current level with the device and continue charging.

### 4.2 PROTECTIVE FEATURES

#### 4.2.1 Short Circuit Protection

The TA202 is capable of surviving a short circuit event without permanent damage. The unit goes into an over-current condition so that the average current is significantly reduced and the device is protected.

#### 4.2.2 Over-Current Protection

The TA202 monitors the current draw individually on each port. During an over-current condition the voltage is reduced. If the voltage falls below 3.8 VDC the output is turned off for a period of 12 seconds. The output is then checked for continued over-current conditions every 16 milliseconds. This condition is referred to as a hiccup mode. The device stays in this mode until the over-current condition is removed, then returns to normal operation.

#### 4.2.3 Low Input Voltage Shutdown

If the input voltage applied to the TA202 drops below 10 VDC the unit will shut down until the applied voltage returns to a level within range.

#### 4.2.4 Over-Temperature

When the internal temperature of the TA202 exceeds designed thresholds, the unit will shut down and stop providing power. When the temperature returns to an acceptable level the unit will automatically begin providing power as required, up to a full charge of 3.0 amps.

## SECTION 5 CONFORMANCE

### 5.1 CONTINUED AIRWORTHINESS STATEMENT

No periodic scheduled maintenance or calibration is necessary for continued airworthiness of the TA202 series Single and Dual USB Charger. If the unit fails to perform to specifications, the unit must be removed and serviced by Mid-Continent Instruments and Avionics or their authorized designee.

### 5.2 ENVIRONMENTAL QUALIFICATION STATEMENT

**MODEL NUMBER:** TA202 Series      **PART NUMBER:** 6430202-( )  
**NOMENCLATURE:** Single and Dual USB Charger  
**CERTIFICATION:** FAA TSO-C71  
**MANUFACTURER:** True Blue Power, a division of Mid-Continent Instrument Co., Inc.  
**ADDRESS:** 9400 E. 34<sup>th</sup> St. North, Wichita, KS 67226, USA.

#### MANUFACTURERS SPECIFICATIONS:

Minimum Performance Specifications: TS365 (03/14/2016), TDS365 (03/14/2016)  
 Qualification Test Reports: QTR2604-2608, QTR2615-2618, QTR2621, QTR2625  
**RTCA DO-160:** Rev G, dated 12/08/10      **DATES TESTED:** 02/2016-03/2016

CONDITIONS	SECTION	DESCRIPTION OF TEST
Temperature and Altitude	4	Category F1
Low Temperature	4.5.1	Operating Low Temp = -40°C
High Temperature	4.5.3	Short Time Operating High Temp = +70°C
High Temperature	4.5.4	Normal Operating High Temp = +55°C
Altitude	4.6.1	Altitude = 55K feet
Temperature Variation	5	Category S2
Humidity	6	Category B
Operational Shock and Crash Safety	7	Category B
Vibration	8	Fixed Wing: Category R, Curves C, C1
Explosion	9	Category X
Waterproofness	10	Category X
Fluids	11	Category X
Sand and Dust	12	Category X
Fungus	13	Category F
Salt Spray	14	Category X
Magnetic Effect	15	Category Z
Power Input	16	Category B(XX)
Voltage Spike	17	Category B
Audio Freq Conducted Susceptibility	18	Category R
Induced Signal Susceptibility	19	Category X
Radio Frequency Susceptibility	20	Category X
Emission of Radio Frequency Energy	21	Category M
Lightning Induced Transient Susceptibility	22	Category X
Lightning Direct Effects	23	Category X
Icing	24	Category X
ESD	25	Category A
Fire, Flammability	26	Category X
REMARKS: Sections 4: Normal operating low temperature was tested to and complies with -40°C. (Category F1 Continuous Operating Low Temperature requirement is -20°C.)		