

## Overview

tailBeacon is a 2020 compliant, near zero-install, Class B1S ADS-B UAT transmitter and WAAS GPS integrated into a rear position light. The power transcoder decodes replies from legacy Mode C and Mode S transponders. 14 CFR §91.227 compliant. Smart phone configurable over Wi-Fi.

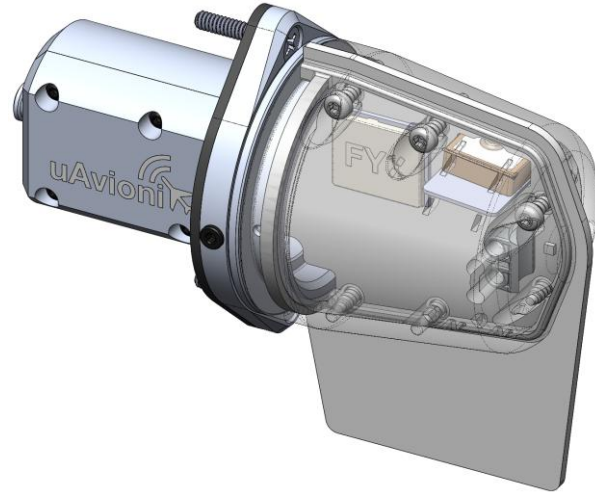

## Features

### UAT Transmitter

- Meets the performance requirements of TSO-154c (RTCA/DO-282B) Class B1S

### Position Light

- Meets performance requirements of TSO-C30c Type III

### WAAS GPS

- Meets the performance requirements of TSO-C145e (RTCA/DO-229E) Class Beta 1
- Integrated RAIM processor for Security and Integrity protection
- SBAS corrections and health messages used to detect and correct satellite range errors
- Satellite pseudo range step errors detected and excluded
- SBAS fast and long-term corrections applied

### Power Transcoder

- Decodes altitude and squawk via aircraft electrical system

### Certification

- Pending TSO certification for installation by Approved Model List (AML) STC on hundreds of aircraft makes and models

Patents Pending

## Regulatory

- FCC ID 2AFFTUAT016R
- ADS-B Out: §91.225, §91.227, AC 20-165B
- GNSS Position: AC 20-165B
- Position Light: SAE/AS8037

## Technical Specifications

| Specification                       | Value                |
|-------------------------------------|----------------------|
| Input Voltage                       | 11-31V DC            |
| Operating Power                     | 3watts               |
| Size                                | 92x43x73mm           |
| Weight                              | 70grams              |
| SDA/SIL                             | 2/3                  |
| Operating Temp                      | -45 to 70°C          |
| 978MHz UAT Transmitter              |                      |
| Power Classification                | DO-282B Medium Power |
| WAAS GPS                            |                      |
| Tracking                            | -166dBm              |
| Reacquisition                       | -160dBm              |
| Cold Start                          | -148dBm              |
| LED Position Light                  |                      |
| Color                               | Aviation White       |
| Intensity                           | 40 candelas          |
| Wi-Fi Configuration                 |                      |
| Physical                            | 802.11b/g/n          |
| App Compatibility                   | iOS, Android         |
| Power Transcoder                    |                      |
| Decodes Mode A,C and S via DC input |                      |

## Operating Limitations

The conditions and tests required for STC approval of tailBeacon are minimum performance standards. The installer must determine if the conditions are appropriate for installation on a specific aircraft.

## Continued Airworthiness

There is no requirement for periodic service, inspection or preventative maintenance for continued airworthiness of tailBeacon.

## 2020 Regulatory Compliance

tailBeacon meets the Minimum Operational Performance Standards of DO-282B Class B1S, and meets the performance requirements of TSO-C154c. When installed in accordance with the installation instructions of this guide, the device complies with the aircraft requirements of 14 CFR 91.227.

## Installation Procedures

tailBeacon is rear position light. The assembly should be mounted as far outboard on the aircraft as practical, parallel to the vertical and horizontal centerlines of the aircraft. Ensure that when mounted, the antenna fin is oriented vertically with the longer fin toward the ground. The top of the assembly should be free from obstructions.

1. Remove the existing aft position light.
2. Detach the power wire(s).
3. Connect the red wire to the switched power wire.
4. tailBeacon may be grounded to the aircraft structure via the mounting screws. However, it may be necessary to connect the black wire to the battery ground.
5. Mount tailBeacon using the two supplied #4 screws. Changes to the existing position light circuit breaker are not required.

## Environmental Specifications

| Conditions                                  | DO-160G Section | Description of Conducted Tests  |
|---|-----------------|---|
| Temperature and Altitude                    | 4.0             | Equipment tested to Category B2   |
| Low temperature ground survival             | 4.5.1           | -55°C   |
| Low Temperature Short-Time Operating        | 4.5.1           | -45°C   |
| Low Temperature Operating                   | 4.5.2           | -45°C   |
| High Temperature Operating                  | 4.5.4           | +70°C   |
| High Temperature Short-Time Operating       | 4.5.3           | +70°C   |
| High Temperature Ground Survival            | 4.5.3           | +85°C   |
| Loss of Cooling                             | 4.5.5           | Cooling air not required (+70°C operating without cooling)  |
| Altitude                                    | 4.6.1           | 25,000feet  |
| Decompression                               | 4.6.2           | Equipment identified as Category B2 – no test   |
| Overpressure                                | 4.6.3           | Equipment identified as Category B2 – no test   |
| Temperature Variation                       | 5.0             | Equipment tested to Category A  |
| Humidity                                    | 6.0             | Equipment tested to Category C  |
| Operation Shocks                            | 7.2             | Equipment tested to Category B  |
| Crash Safety                                | 7.3             | Equipment tested to Category B type 5   |
| Vibration                                   | 8.0             | Aircraft zone 5: type 4 (Multi Engine) to Category S level L, type 5 (Single Engine) to Category S level M<br>Aircraft zone 3: type 1 (Helicopters) to Category U level H |
| Explosion                                   | 9.0             | Equipment identified as Category X – no test  |
| Waterproofness                              | 10.0            | Equipment identified as Category S  |
| Fluids Susceptibility                       | 11.0            | Equipment identified as Category X – no test  |
| Sand and Dust                               | 12.0            | Equipment identified as Category S  |
| Fungus                                      | 13.0            | Equipment identified as Category X – no test  |
| Salt Spray                                  | 14.0            | Equipment identified as Category S  |
| Magnetic Field                              | 15.0            | Equipment identified as Category B  |
| Power Input                                 | 16.0            | Equipment identified as Category BX   |
| Voltage Spike                               | 17.0            | Equipment identified as Category B  |
| AF Conducted Susceptibility                 | 18.0            | Equipment identified as Category B  |
| Induced Signal Susceptibility               | 19.0            | Equipment identified as Category AC   |
| RF Susceptibility                           | 20.0            | Equipment identified as Category TT   |
| RF Emissions                                | 21.0            | Equipment identified as Category B  |
| Lightening Induced Transient Susceptibility | 22.0            | Equipment identified as Category XXXX – no test   |
| Lightening Direct Effects                   | 23.0            | Equipment identified as Category X – no test  |
| Icing                                       | 24.0            | Equipment identified as Category X – no test  |
| Electrostatic Discharge                     | 25.0            | Equipment identified as Category X – no test  |
| Fire, Flammability                          | 26.0            | Equipment identified as Category C  |

## Configuration Procedures

Download the “uAvionix skyBeacon Installer” app from the iOS App store or Google Play.

Connect to skyBeacon



Turn on power to your skyBeacon



Connect to the skyBeacon Wi-Fi network (Beacon-xxxx)

OPEN WI-FI SETTINGS



Return to this app to continue

## CONFIGURE

### Anonymous Mode:

When checked, this enables the tailBeacon to transmit a self-assigned ICAO and sets a random Call Sign when the squawk code matches the defined VFR squawk code (1200). When enabled, the operator will not be eligible to receive ATC services.

### Call Sign:

The CALL SIGN can be up to an 8 digit code that corresponds to the tail number of the aircraft.

Note: This is typically your aircraft N-number (eg N12345)

### ICAO Number:

The ICAO address is a 24-bit number issued to the aircraft by the registration authority of the aircraft. These addresses are usually written as a 6-digit hexadecimal number expressed with 0-9 and A-F.

### Emitter Type:

To assist ATC tracking of aircraft, an aircraft category can be transmitted. Select the aircraft category that most closely matches the aircraft.

### Vso (knots):

This parameter allows tailBeacon to automatically switch between airborne and ground modes.

### ADS-B In Capability:

Sets the ADS-B In equipment capability reporting.

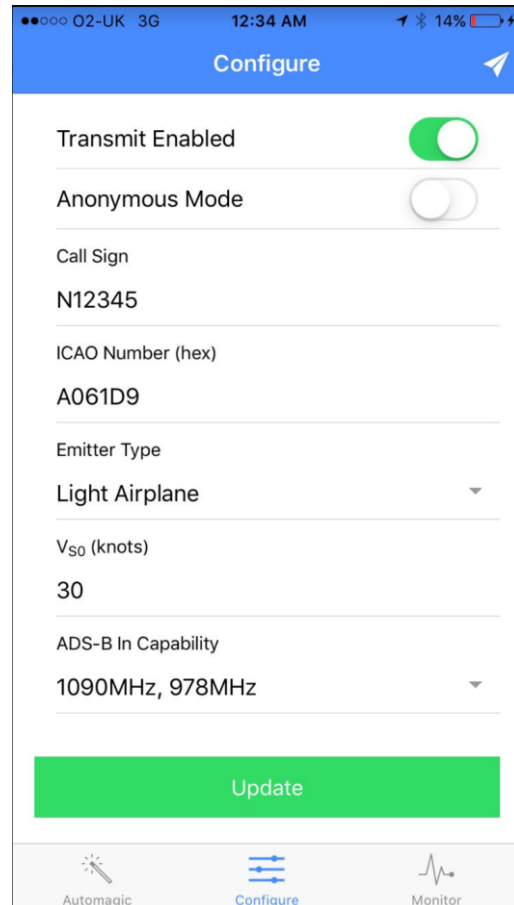

## MONITOR

The monitor screen allows the installer to check the configuration parameters and internal operation of tailBeacon, such as the GPS position and transponder reply decoder.

## Operating Procedures

tailBeacon must be enabled (turned ON) during all phases of flight including surface movement operations.

### System Status (RED) LED Operation:

| LED Operation | Meaning   |
|---------------|---|
| On (Constant) | Device Failure<br>Internal Self-test failure<br>Invalid ICAO configured |
| Blinking      | Function Failure<br>No GPS Signal<br>ADS-B Broadcast Failure            |
| Off           | No Failure  |

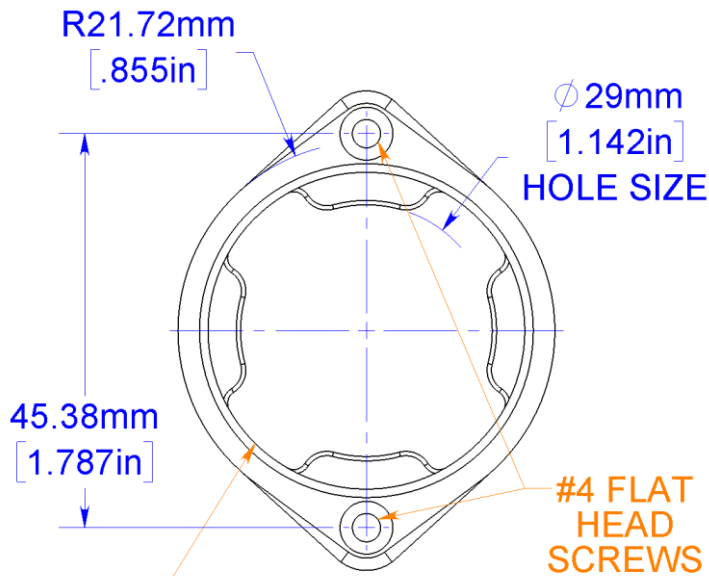
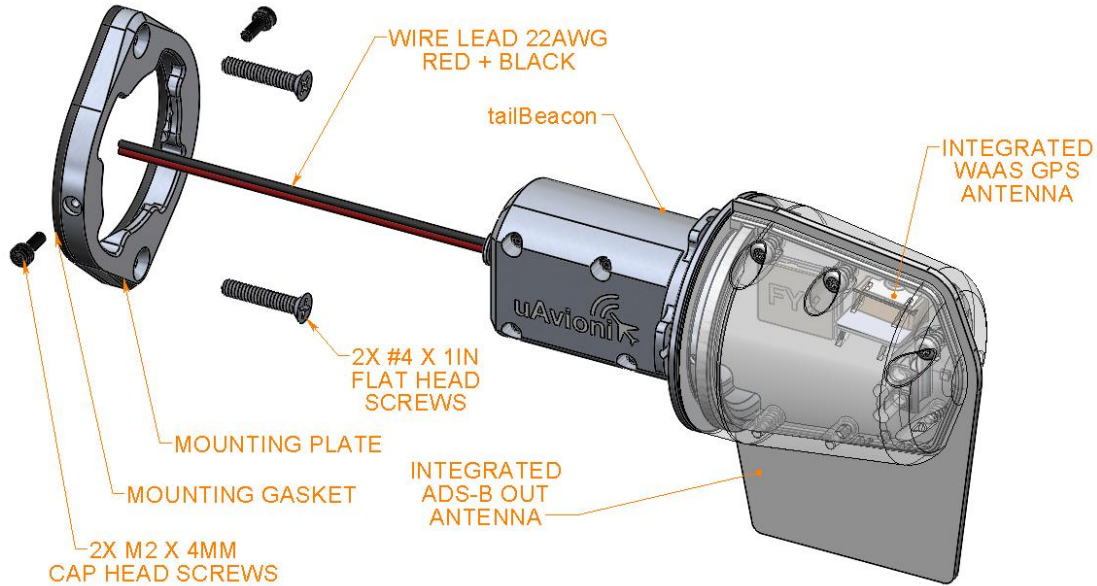

**MOUNTING RING CAN BE INSTALLED WITH SCREWS HORIZONTAL OR VERTICAL**

uAvionix products are warranted to be free from defects in material and workmanship for one year from the date of installation in the aircraft. For the duration of the warranty period, uAvionix, at its sole option, will repair or replace any product which fails in normal use. Such repairs or replacement will be made at no charge to the customer for parts or labor, provided that the customer shall be responsible for any transportation cost.