



Deklin Technologies

AIU-900

Autopilot Interface Unit

Installation Manual

Rev 2.3 Dec 18, 2020

Deklin Technologies Inc

Tel: (615) 819-0800 Fax: (615) 819-0801
www.deklintech.com

REVISIONS

REV	DESCRIPTION	DATE	APPROVAL
1.0	Initial Release	March 5, 2011	JAD
1.1	Certification requirements, parts list update	April 15, 2014	JAD
1.2	Add AIU900C, General Clean up	Nov 6, 2017	JAD
2.0	Rmv AIU900C, Add AIU900D, Update Dwgs	Apr 28, 2019	JAD
2.1	Correct Minor Errors	Dec 6, 2019	JAD
2.2	Add GI 275 Interface Drawings	Aug 10, 2020	JAD
2.3	Add AIU-900E & AIU-900F Versions Add GI-275 Interface Drawings	Dec 23, 2020	JAD

TABLE OF CONTENTS

Section I General Information

INTRODUCTION _____	1
SCOPE _____	1
EQUIPMENT DESCRIPTION _____	1
SPECIFICATIONS _____	2
General Specifications _____	2
Input Specifications _____	2
Component List _____	2
EQUIPMENT SUPPLIED _____	2
PARTS REQUIRED BUT NOT SUPPLIED _____	2

Section II Installation

GENERAL INFORMATION _____	3
Scope _____	3
Installation Requirements _____	3
Unpacking and Inspection _____	3
INSTALLATION PROCEDURES _____	3
Cooling Requirements _____	3
Mounting Requirements _____	3
Cable harness Wiring _____	3
Noise _____	4
Post Installation Checks _____	4
Operational Check Out _____	4

Section III Warranty and Service

WARRANTY _____	5
FACTORY SERVICE _____	5

Appendix A – Schematics

AIU-900A Schematic _____	6
AIU -900A Connector Map _____	7
AIU -900B Schematic _____	8
AIU -900B Connector Map _____	9
AIU -900D Schematic _____	10
AIU -900D Connector Map _____	11
AIU -900E Schematic _____	12
AIU -900E Connector Map _____	13
AIU -900F Schematic _____	14
AIU -900F Connector Map _____	15

Appendix B – Interconnect Drawings

AIU-900 SERIES INSTALLATION NOTES _____	16
ACU TO 1C388/388MC/388C388MC (AIU-900B) _____	17
ACU TO 1C388-2/388-3 (AIU-900B) _____	18
ACU TO NO COUPLER (AIU-900B) _____	19
GDU620 TO 1C388/388MC/388C388MC (AIU-900A) _____	20
GDU620 TO 1C388-2/388-3 (AIU-900A) _____	21

TABLE OF CONTENTS...continued

GDU700/1060 TO 1C388/388MC/388C388MC (AIU-900D) _____	22
GDU700/1060 TO 1C388-2/388-3 (AIU-900D) _____	23
GAD29B TO 1C388/388MC/388C388MC (AIU-900A) _____	24
GAD29B TO AUTOPILOT W/1C388-2/388-3 (AIU-900A) _____	25
GI-275 TO 1C388/388MC/388C388MC (AIU-900D) _____	26
GI-275 TO W/1C388-2/388-3 (AIU-900A) _____	27
GI 275 TO CENTURY AUTOPILOT 1C388/388C/388M/388MC (AIU-900E) _____	28
GI 275 TO CENTURY AUTOPILOT 1C388-2/388-3 (AIU-900F) _____	29
Appendix C – Mechanical _____	30

Section I General Information

INTRODUCTION

This manual contains information regarding the physical, mechanical, and electrical characteristics, plus, the installation requirements for the AIU-900 series Autopilot Interface Unit.

SCOPE

This manual provides detailed installation instructions for the AIU-900 series Autopilot Interface Unit.

EQUIPMENT DESCRIPTION

The Deklin Technologies, Inc. AIU-900 series are a pre-assembled autopilot interface unit following the interconnect specifications and component requirements recommended by the manufacturers of certain PFD systems when interfaced with existing 1C388 series autopilot couplers. It is intended to provide a convenient solution in a single device with multiple variations for installers to use in place of producing the same circuits from discrete components as specified in PFD installation manuals. The installer is responsible to certify as airworthy and determine eligibility of this product for installation IAW FAA Parts 21 and 43, IAW AC20-62E, Section 11, Paragraph a.

11. ELECTRICAL PARTS AND INSTRUMENTS.

a. Electronic Kits.

Kits assembled by non-certificated individuals are not eligible for installation on TC'd aircraft until the part is certified as airworthy and found eligible for installation in accordance with parts 21 and 43. During and after assembly, these kits should receive documented conformity inspections by properly certificated persons to ensure they meet all applicable airworthiness requirements for use on the specified aircraft on which they are to be installed. The installation of these approved units should be accomplished by or under the supervision of a properly certificated person or agency in accordance with parts 21 and 43. When the installation is a major alteration, the kit data and the data used for the alteration of the product must be approved by a representative of the Administrator. An appropriately certificated person must complete the maintenance records to ensure that the aircraft is approved and airworthy for return to service.

The AIU-900 series equipment compatibility:

- EFD1000[®] PFD to Century 1C388 series autopilot couplers.
- E5[®] PFD to Century 1C388 series autopilot couplers.
- G5[®], G500[®], G500TXi[®], and GI 275[®] PFDs to Century 1C388 series autopilot couplers.
- GI 275[®] PFDs to Century autopilot computers.

EFD1000 E5 are Copyrighted by Aspen Avionics.

G5, G500, GI 275 and G500TXi are Copyrighted by Garmin International.

SPECIFICATIONS

General Specifications

Case Material:	5052H32 Aluminum Chassis and Cover
Dimensions: <i>(not including mating connector)</i>	4.60" (116.8mm) X 2.56" (65.0mm) X 1.50" (38.1mm)
Weight:	0.25 Lbs - 0.38 Lbs (0.11 Kg - 0.17 kg)
Connectors:	25 Pin Female D-Sub Connector
Mounting:	Bulkhead, Four 8/32 Screws

Input Specifications

Input Voltage:	Not Applicable
Current:	Not Applicable

Component List AIU-900A

Capacitors:	0.047uF Metalized Polyester, 100V
Inductor, Choke:	18 mH
Resistors:	10.0 kOhm 0.25W, 1% (x3)
Transformers:	SP-66 (x3)

Component List AIU-900B

Capacitors:	0.027uF, Metalized Polyester, 100V
Inductor, Choke:	27mH
Resistors:	10 kOhm (x3), 100 kOhm 0.25W, 1%
Trim Pots:	5 kOhm, 200 kOhm Single Turn, Side Adj
Transformers:	SP-66, SP67 (x2)

Component List AIU-900D

Capacitors:	0.047uF Metalized Polyester, 100V
Inductor, Choke:	18 mH
Resistors:	10 kOhm 0.25W, 1% (x2)
Transformers:	SP-66, SP-13

Component List AIU-900E

Resistors:	2.2 kOhm 0.25W, 1% (x2)
Transformers:	SP-13 (X2)

Component List AIU-900F

Resistors:	2.2 kOhm 0.25W, 1% (x2), 10 kOhm 0.25W, 1%
Transformers:	SP-13 (X2), SP-66

EQUIPMENT SUPPLIED

1	each	AIU-900 Series
---	------	----------------

PARTS REQUIRED BUT SUPPLIED WITH UNIT

1	each	AIU-900IK Installation Kit
---	------	----------------------------

May be purchased separately from Deklin Technology or supplied by installer.

Section II - Installation

GENERAL INFORMATION

Scope

This manual is for reference only and should not be used as Return to Service authorization. Refer to OEM specific installation instructions for installation requirements.

This section provides detailed installation and interconnection instructions for the AIU-900 Autopilot Interface Unit. Please read this manual carefully before beginning any installation to prevent damage and post installation problems. Installation of this equipment requires special knowledge and tools

Installation Requirements

The AIU-900 requires specialized knowledge and tools for an effective installation. An appropriately rated Certified Repair Station must install this equipment in accordance with applicable regulations. Deklin Technologies, Inc warranty is not valid unless installed by an authorized FAA approved repair station. Failure to follow any of the installation instructions, or installation by a non-certified individual or agency will void the warranty and may result in a non-airworthy installation.

Unpacking and Inspection

Use care when unpacking the equipment. Inspect the unit and all the parts supplied for visible signs of shipping damage. Examine the unit for loose or broken pieces. Verify the correct quantity of components supplied with the list in Section I. If any damage claim is to be made, save the shipping material and contact the freight carrier. Do not attempt to install a damaged unit. Equipment returned to Deklin Technologies, Inc for any other reason should be shipped in the original packaging, or other UPS approved packaging. Return any damaged items to the vendor from which it was purchased.

INSTALLATION PROCEDURES

Cooling Requirements

Forced air-cooling is not required for the AIU-900. However, the equipment should be kept away from heat sources without adequate cooling provided. (i.e. defrost or heating ducts, dropping resistors, heat producing avionics.)

Mounting Requirements

The AIU-900 must be mounted inside the pressure vessel in a temperature controlled environment unless the aircraft's service ceiling is less than 25,000 feet.

The AIU-900 must be rigidly mounted to a secure structure in accordance with FAA Advisory Circulars AC 43.13-1B and AC 43.13-2B. The unit should be mounted in an area with adequate clearance for the unit and associated wiring.

Cable Harness Wiring

All wires must be MIL-SPEC in accordance with current regulations and/or OEM specific requirements. All shielded wire should be MIL-C-27500 or equivalent (with solder sleeves for shield termination) and must be used where specified. Proper stripping, shielding and soldering techniques must be used at all times.

Refer to FAA Advisory Circulars AC 43.13-1B and AC 43.13-2B for more information. Failure to use correct techniques may result in improper operation, electrical noise, and/or unit failure. Damage caused by improper installation will void warranty.

Noise

Due to the variety and high power of equipment in today's aircraft, there is a potential for both electrical and conducted noise interference. To minimize the occurrence of noise being introduced, please follow these installation guidelines.

Do not bundle any lines from this unit with transmitter coax lines.

Do not bundle any lines from this unit with any other audio or high voltage power lines.

Do not bundle any lines from this unit with 400 Hz synchro wiring or AC power lines such as strobes or inverters.

Do not position this unit or route wiring from this unit next to any device with a strong alternating magnetic field such as an inverter.

Use shielded wire where shown and ground as indicated.

Post Installation Check

After installation wiring is complete, verify no power is on any pin and airframe ground on pin 5 only.

Operational Checkout

Follow instructions in specific OEM PFD Installation Manuals for check out procedures.

Section III – Warranty and Service

WARRANTY

Deklin Technologies, Inc. warrants this product to be free from defect in workmanship and material for a period of 24 months from the time of installation or 26 months from the factory shipping date. This warranty is valid only if the equipment is installed in an aircraft by a FAA certified avionics facility (or other ICAO agency).

If during the warranty period this unit should fail it will be at the discretion of Deklin Technologies, Inc to send a replacement unit or repair the original unit. All units must be returned to the factory for repair or replacement.

All shipping and handling charges for the return of a unit to the factory are the responsibility of the purchaser. Domestic UPS Ground shipping charges for sending an exchange or repaired unit to the customer will be the responsibility of Deklin Technologies, Inc. Any additional charges as a result of requested improved delivery time, alternate carrier, insurance, or handling costs are the responsibility of the customer. All freight, handling, insurance, brokerage fees, duties and/or taxes for shipments outside the continental United States are the responsibility of the purchaser.

Deklin Technologies, Inc shall not be liable for incidental or consequential damages. This warranty does not cover a defect that has resulted from improper installation, handling, storage or preservation, unreasonable use, or maintenance. This warranty does not cover expenses incurred for the removal and/or installation of this product.

All items repaired or replaced under this warranty are warranted for the remainder of the original warranty period. Deklin Technologies, Inc reserves the rights to make modifications or improvements to the product without obligation to perform like modifications or improvements to previously manufactured products.

FACTORY SERVICE

In the event any unit needs to be returned to the factory contact Deklin Technologies, Inc for a Return Authorization Number prior to returning. Units that arrive without a Return Authorization Number, will be returned un-repaired. Deklin Technologies, Inc is not responsible for items returned via Mail.

Appendix A - Schematics

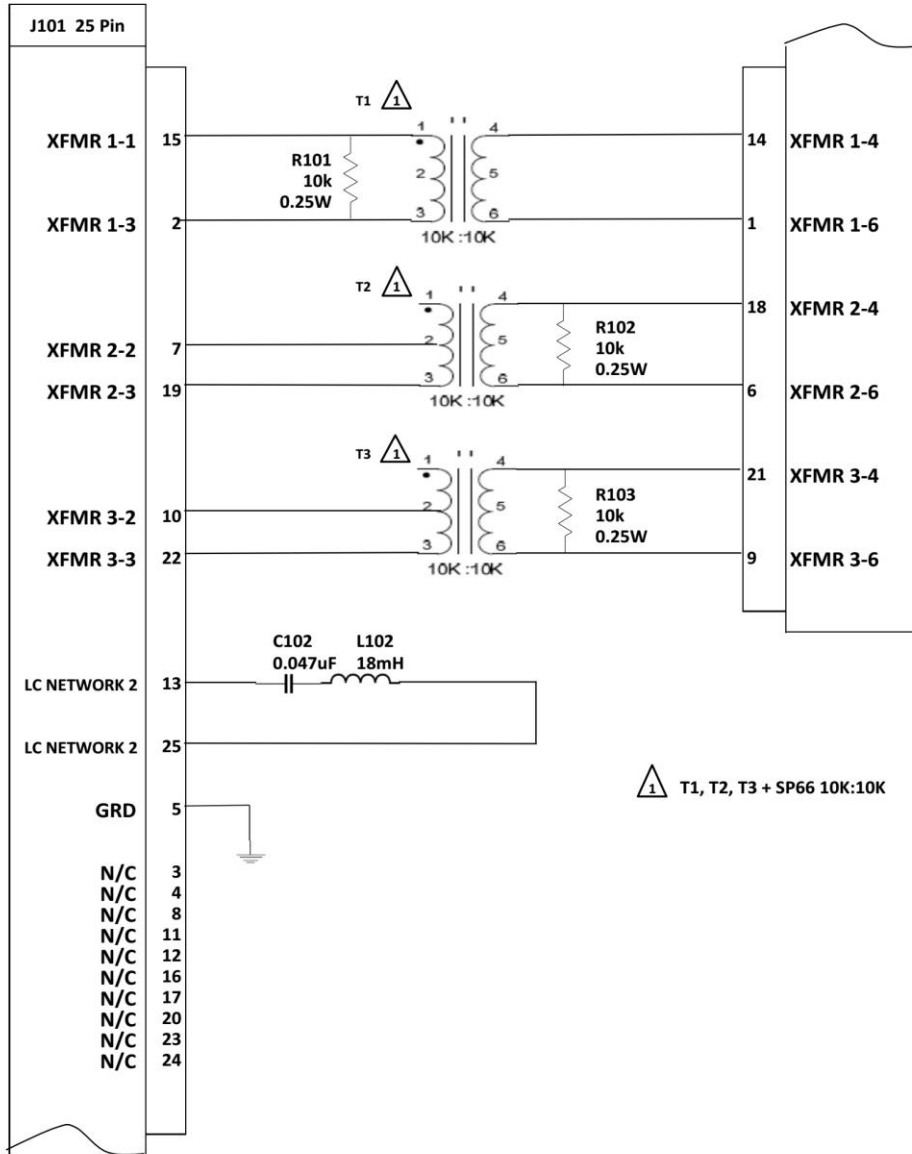

T1, T2, T3 + SP66 10K:10K

CONFIDENTIAL AND PROPRIETARY TO DEKLIN TECHNOLOGIES INC

DATE:	Dec 4/2019	Deklin Technologies <small>www.deklintech.com</small>					
DRAWN BY	JAD						
CHECKED	JAD						
APPROVED	JAD	TITLE	AIU-900A AUTOPILOT INTERFACE SCHEMATIC				
PART NO.	AIU-900A	SIZE	A	REV.	2.21	SHEET	1 of 1
FILE		DWG TYPE	SCHEMATIC		DWG NO.		

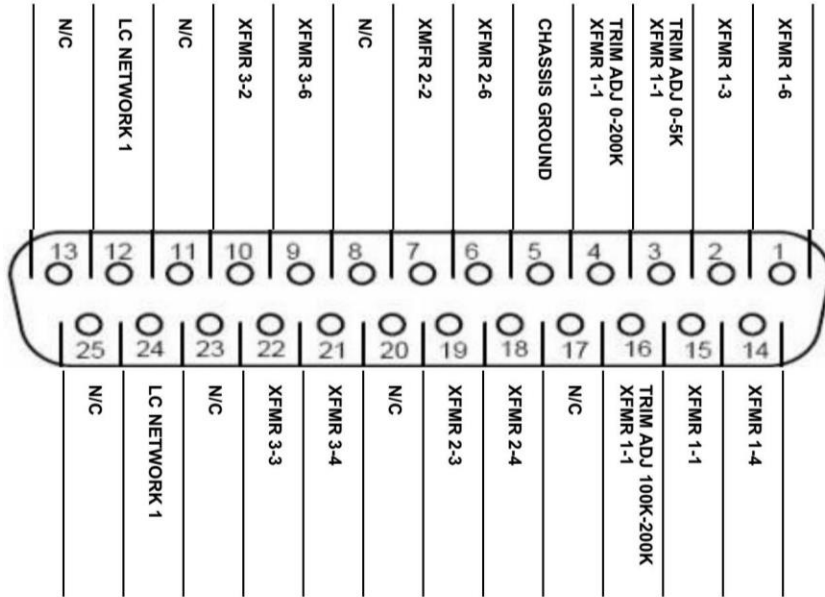

Note: View is from Rear of Mating Connector

CONFIDENTIAL AND PROPRIETARY TO DEKLIN TECHNOLOGIES INC.

DATE:	15-Dec-20	 Deklin Technologies www.deklintech.com
DRAWN BY	JAD	
CHECKED	JAD	
APPROVED	JAD	TITLE 25 Pin D-Sub Pin Out AIU-900A
PART NO.		SIZE A REV. 1 SHEET
FILE		DWG TYPE INTERCONNECT DWG NO.

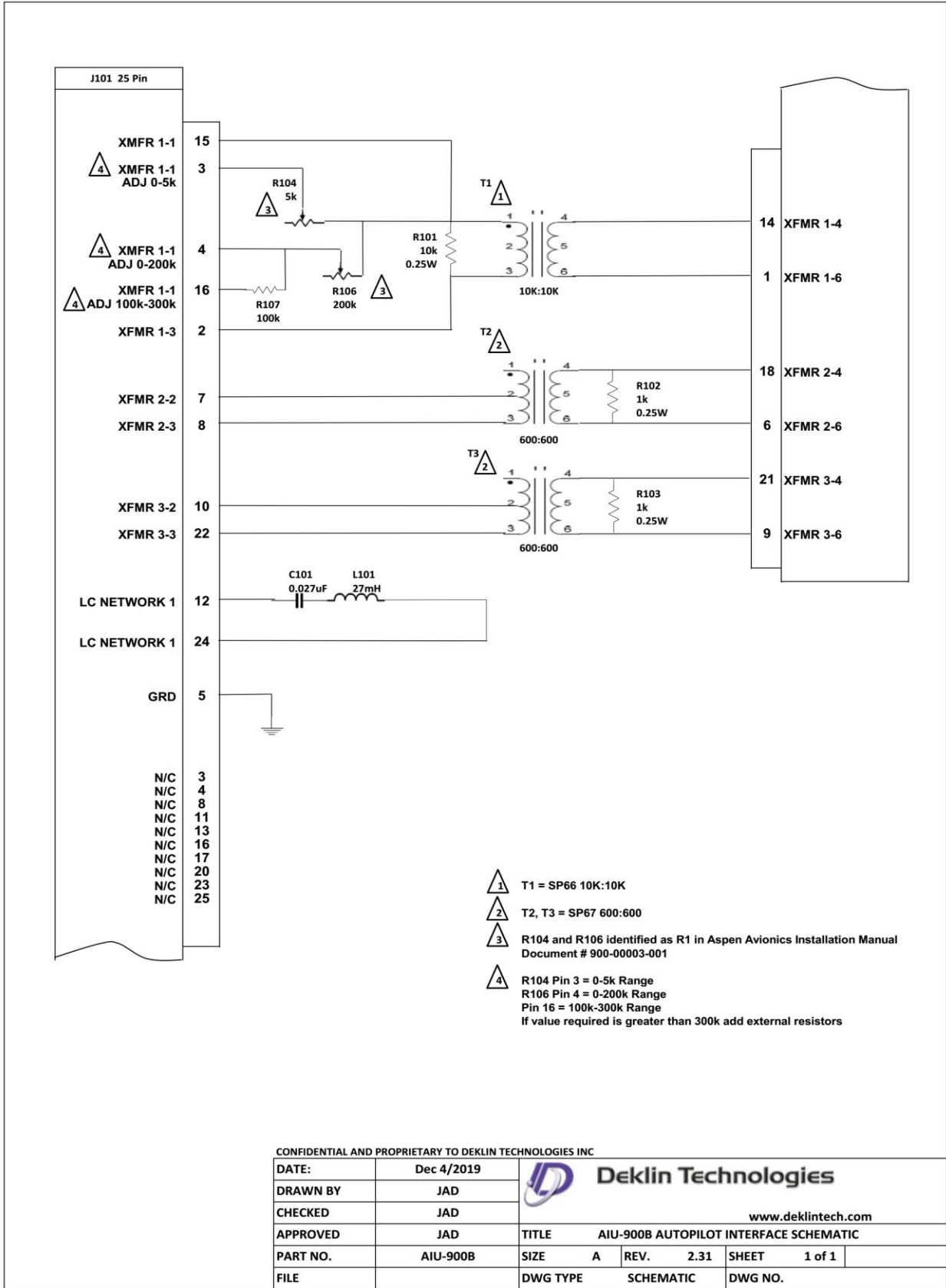

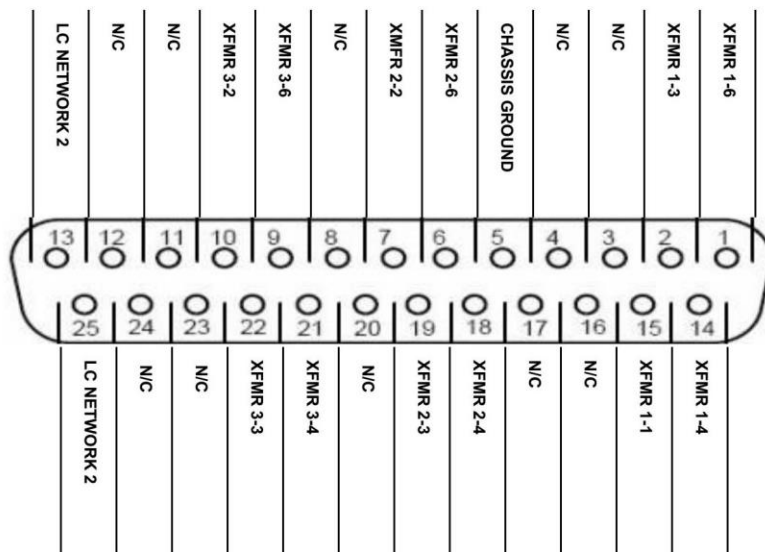



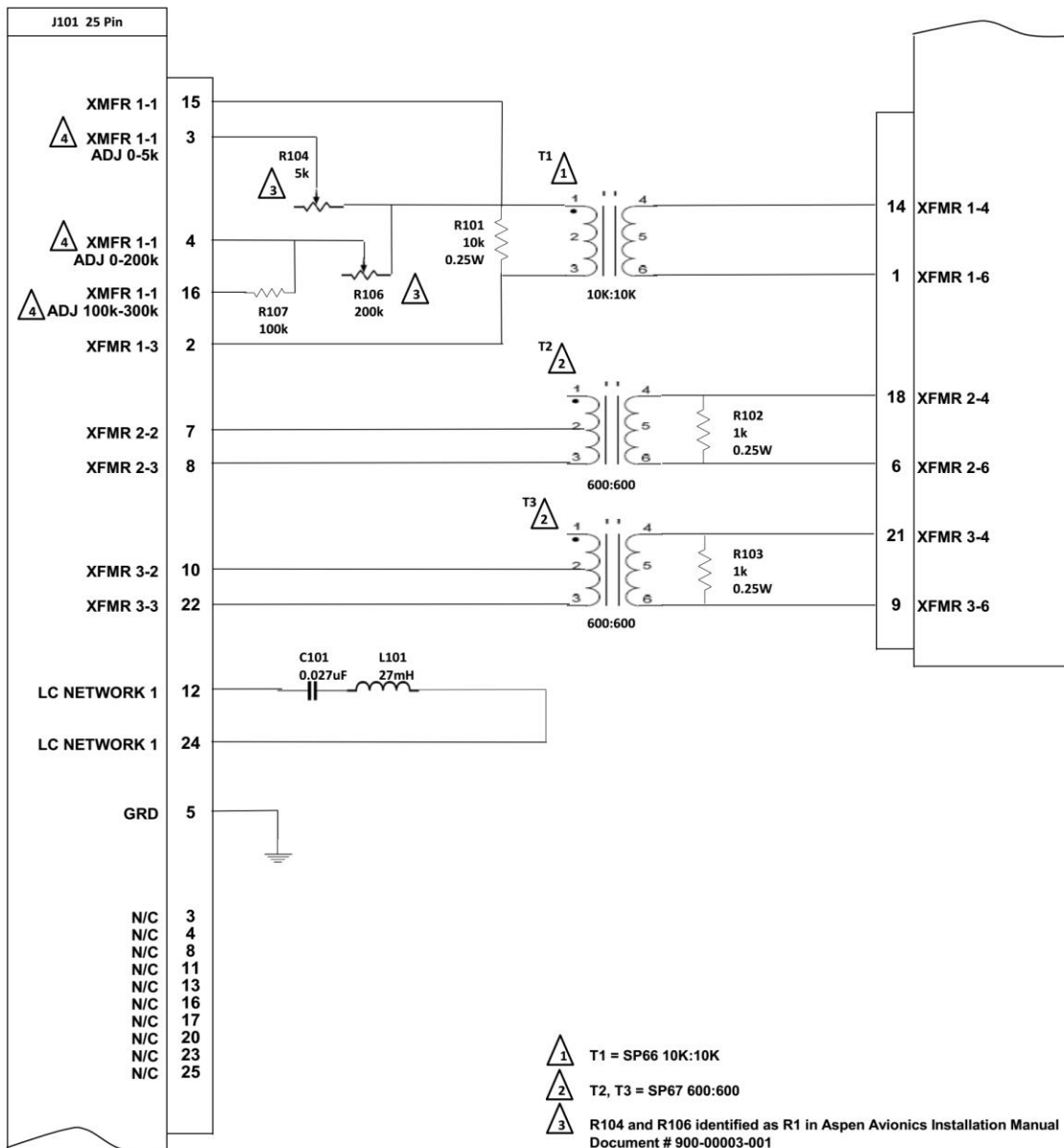

Note: View is from Rear of Mating Connector

CONFIDENTIAL AND PROPRIETARY TO DEKLIN TECHNOLOGIES INC.

DATE:	15-Dec-20	 www.deklintech.com					
DRAWN BY	JAD						
CHECKED	JAD						
APPROVED	JAD	TITLE	25 Pin D-Sub Pin Out AIU-900B				
PART NO.		SIZE	A	REV.	1	SHEET	
FILE		DWG TYPE	INTERCONNECT	DWG NO.			



-  T1 = SP66 10K:10K
-  T2, T3 = SP67 600:600
-  R104 and R106 identified as R1 in Aspen Avionics Installation Manual Document # 900-00003-001
-  R104 Pin 3 = 0-5k Range
R106 Pin 4 = 0-200k Range
Pin 16 = 100k-300k Range
If value required is greater than 300k add external resistors

CONFIDENTIAL AND PROPRIETARY TO DEKLIN TECHNOLOGIES INC

DATE:	Dec 4/2019		Deklin Technologies				
DRAWN BY	JAD						
CHECKED	JAD	www.deklintech.com					
APPROVED	JAD	TITLE	AIU-900B AUTOPILOT INTERFACE SCHEMATIC				
PART NO.	AIU-900B	SIZE	A	REV.	2.31	SHEET	1 of 1
FILE		DWG TYPE	SCHEMATIC		DWG NO.		

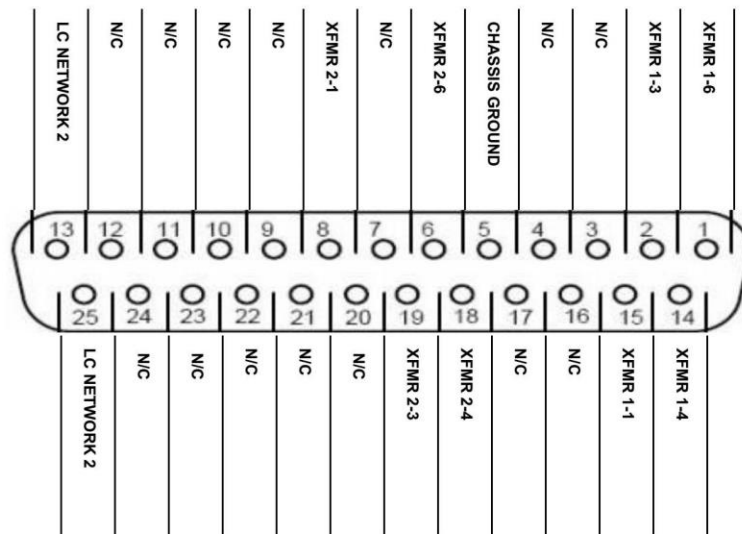

Note: View is from Rear of Mating Connector

CONFIDENTIAL AND PROPRIETARY TO DEKLIN TECHNOLOGIES INC.

DATE:	15-Dec-20	 www.deklintech.com					
DRAWN BY	JAD						
CHECKED	JAD						
APPROVED	JAD	TITLE	25 Pin D-Sub Pin Out AIU-900D				
PART NO.		SIZE	A	REV.	1	SHEET	
FILE		DWG TYPE	INTERCONNECT	DWG NO.			

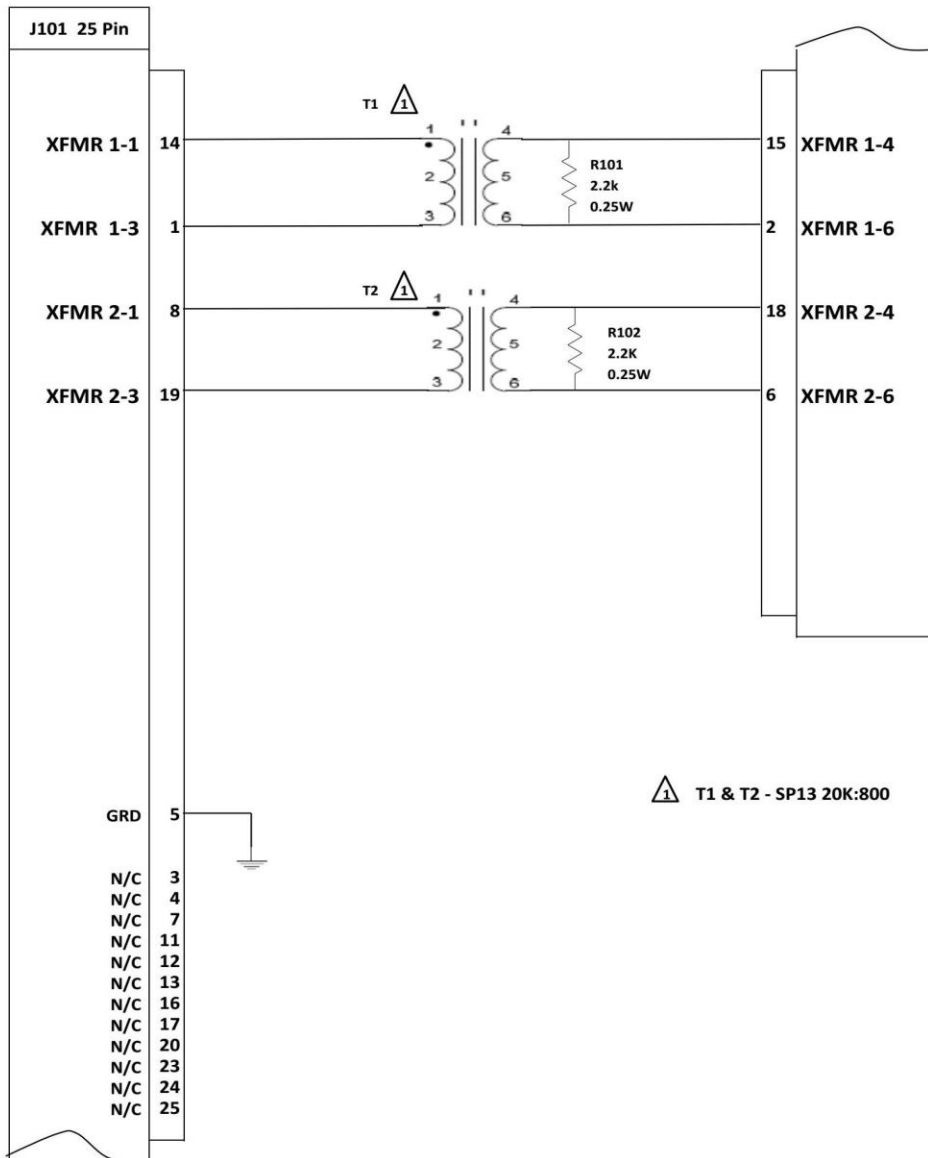

CONFIDENTIAL AND PROPRIETARY TO DEKLIN TECHNOLOGIES INC

DATE:	Dec 15/2020	 www.deklintech.com					
DRAWN BY	JAD						
CHECKED	JAD						
APPROVED	JAD	TITLE	AIU-900E AUTOPILOT INTERFACE				
PART NO.	AIU-900E	SIZE	A	REV.	1	SHEET	1 of 1
FILE		DWG TYPE	SCHEMATIC		DWG NO.		

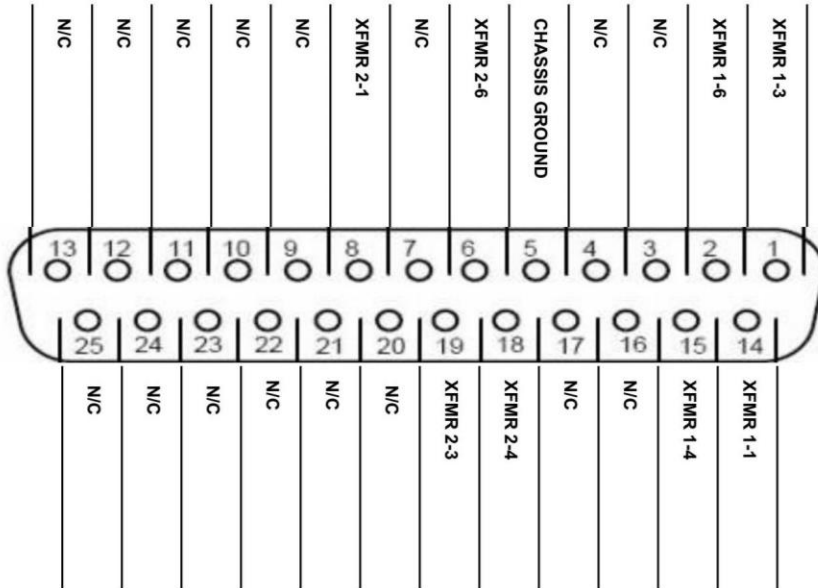

Note: View is from Rear of Mating Connector

CONFIDENTIAL AND PROPRIETARY TO DEKLIN TECHNOLOGIES INC.

DATE:	15-Dec-20						
DRAWN BY	JAD						
CHECKED	JAD	www.deklintech.com					
APPROVED	JAD						
PART NO.		TITLE	25 Pin D-Sub Pin Out AIU-900E				
FILE		SIZE	A	REV.	1	SHEET	
		DWG TYPE	INTERCONNECT		DWG NO.		

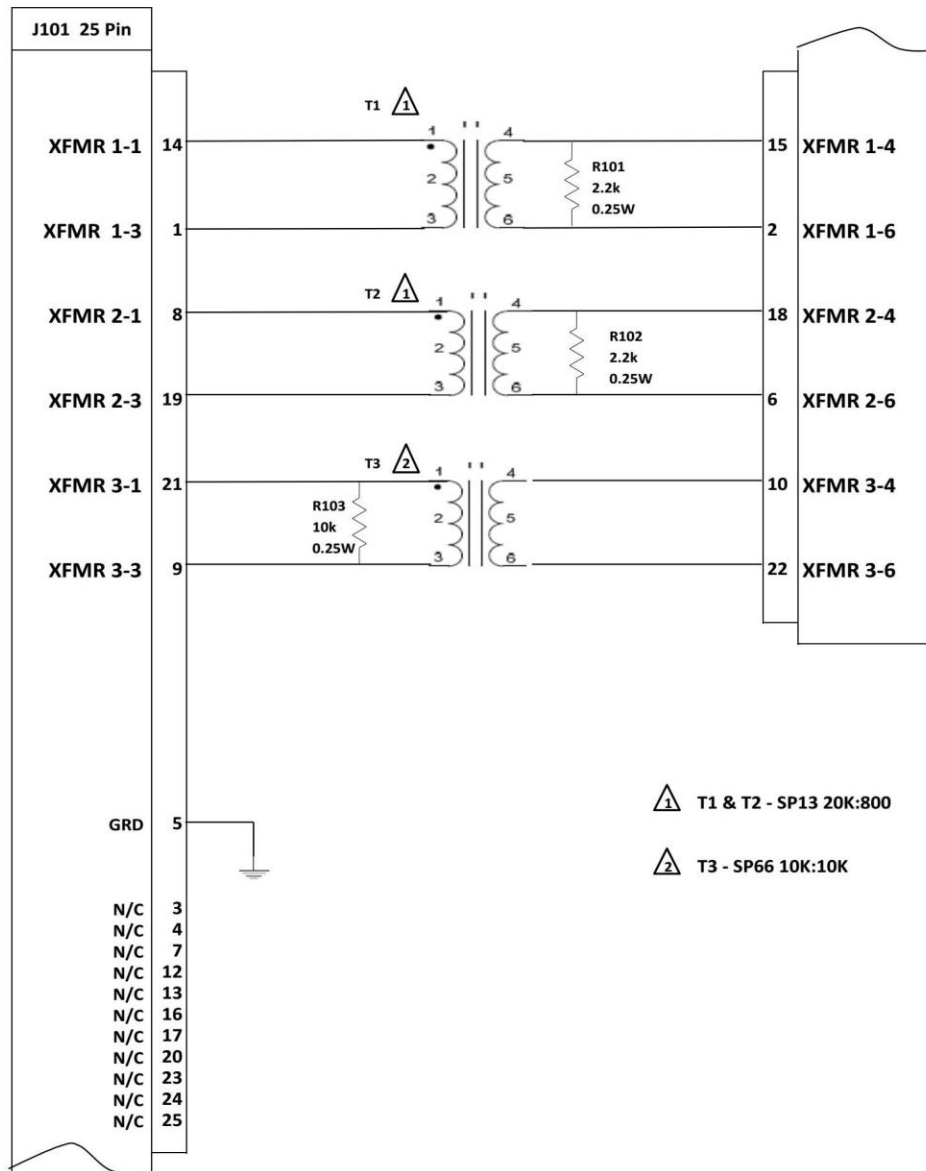

CONFIDENTIAL AND PROPRIETARY TO DEKLIN TECHNOLOGIES INC

DATE:	Dec 15/2020	 Deklin Technologies www.deklintech.com					
DRAWN BY	JAD						
CHECKED	JAD						
APPROVED	JAD	TITLE	AIU-900F AUTOPILOT INTERFACE				
PART NO.	AIU-900F	SIZE	A	REV.	1	SHEET	1 of 1
FILE		DWG TYPE	SCHEMATIC		DWG NO.		

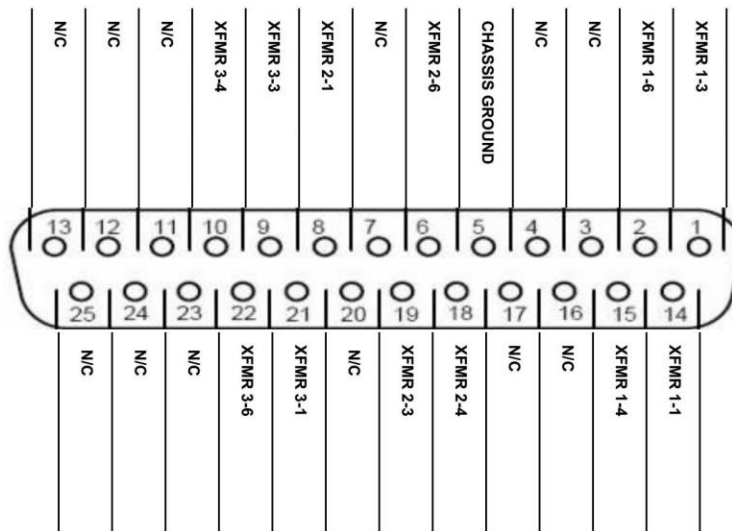

Note: View is from Rear of Mating Connector

CONFIDENTIAL AND PROPRIETARY TO DEKLIN TECHNOLOGIES INC.

DATE:	15-Dec-20	 Deklin Technologies www.deklintech.com
DRAWN BY	JAD	
CHECKED	JAD	
APPROVED	JAD	TITLE 25 Pin D-Sub Pin Out AIU-900F
PART NO.		SIZE A REV. 1 SHEET
FILE		DWG TYPE INTERCONNECT DWG NO.

Appendix B – Interconnect Drawings

AIU-900 SERIES INSTALLATION NOTES

- 1 UNLESS OTHERWISE SPECIFIED BY THE MANUFACTURER OF THE DEVICE BEING INTERFACED TO, ALL WIRES SHOULD 22AWG. ALL UNSHIELDED WIRE SHALL BE SELECTED IN ACCORDANCE WITH AC43.13-1B, CHANGE 1, PARAGRAPHS 11-76 THROUGH 11-78. WIRE TYPES SHOULD BE TO MIL-W-22759 AS SPECIFIED IN AC43.13-1B, CHANGE 1, PARAGRAPHS 11-85 AND 11-86, AND, BE LISTED IN TABLE 11-11. ALL SHIELDED WIRE/CABLE SHALL BE IN ACCORDANCE WITH MIL-C-27500.

- 2 GROUNDED LESS THAN 1 FOOT (0.3 METERS) FROM INTERFACE CONNECTOR.

- 3 SHIELDS SHOULD BE GROUNDED TO AIRFRAME GROUND WITH THE SHORTEST LENGTH OF WIRE POSSIBLE.

- 4 THERE ARE THREE RESISTANCE RANGES AVAILABLE ON THE AIU-900B: R104 (0-5K OHM); R106 (0-200K OHM); AND R106 PLUS 100K OHM RESISTOR (100K-200K OHM). THE OPTIMAL OUTPUT PIN SHOULD BE CHOSEN FOR THE TYPE/MODEL OF THE RADIO COUPLER CONNECTED TO. REFER TO MANUFACTURER'S SPECIFICATIONS. ADDITIONAL EXTERNAL RESISTANCE MAY BE REQUIRED.
R104 AND R106 IDENTIFIED AS R1 IN ASPEN AVIONICS INSTALLATION MANUAL DOCUMENT # 900-00003-001

- 5 PROVIDE SHORT WIRE CONNECTION.

- 6 SPLICE BOTH WIRES TOGETHER INTO PIN B OF CD33 TO AMP.

- 7 THIS DEVICE IS INTENDED TO SIMPLIFY THE INTERFACE OF CERTAIN DEVICES USING SPECIFIC COMPONENTS ALREADY SPECIFIED WITHIN THE INSTALLATION MANUALS OF THESE DEVICES. THESE DRAWINGS AS THEY PERTAIN TO THESE INSTALLATIONS ARE FOR REFERENCE ONLY. REFER TO SPECIFIC MANUFACTURER'S INSTRUCTIONS FOR ACTUAL INTEGRATION.

- 8 REFER TO SPECIFIC MANUFACTURER'S DOCUMENTATION FOR AUTOPILOT INTEGRATION INFORMATION INCLUDING STC COMPLIANCE.

- 9 **THE INSTALLER IS RESPONSIBLE TO CERTIFY AS AIRWORTHY AND DETERMINE THE ELIGIBILITY OF THIS PRODUCT FOR INSTALLATION IAW FAA PARTS 21 AND PART 43, AND AC20-62E, SECTION 11, PARAGRAPH A.**

DATE:	FEB 17/2019		Deklin Technologies				
DRAWN BY	JAD						
CHECKED	JAD						
APPROVED	JAD	TITLE AIU-900 SERIES APPENDIX - B NOTES					
PART NO.		SIZE	A	REV.	1.2	SHEET	
FILE		DWG TYPE	NOTES		DWG NO.		

For reference only. Refer to PFD Manufacturers' instructions

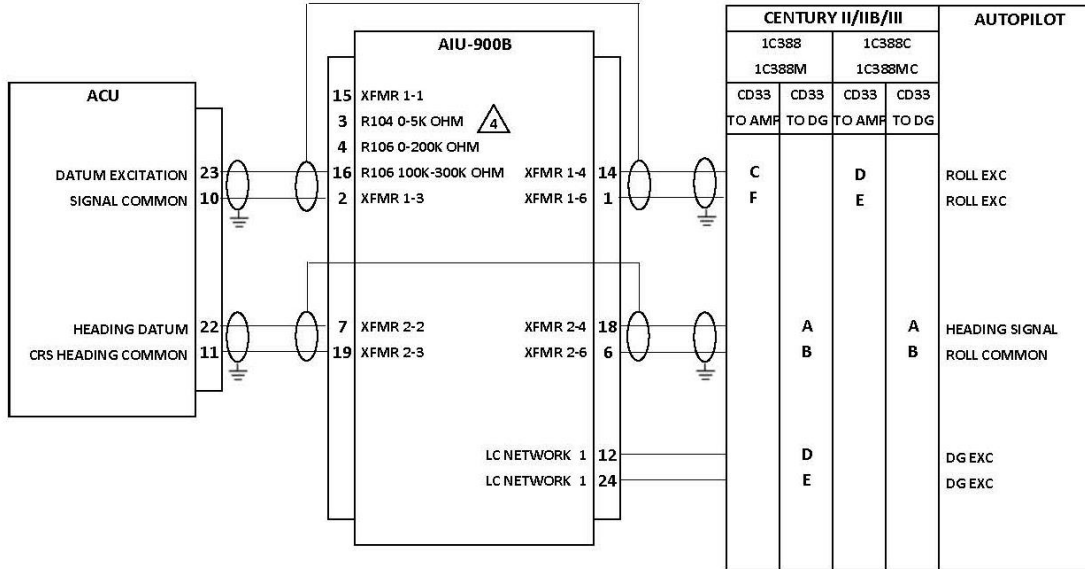

THERE ARE THREE RESISTANCE RANGES AVAILABLE ON THE AIU-900B: R104 (0-5K OHM); R106 (0-200K OHM); AND R106 PLUS 100K OHM RESISTOR (100K-200K OHM). THE OPTIMAL OUTPUT PIN SHOULD BE CHOSEN FOR THE TYPE/MODEL OF THE RADIO COUPLER CONNECTED TO. REFER TO MANUFACTURER'S SPECIFICATIONS. ADDITIONAL EXTERNAL RESISTANCE MAY BE REQUIRED.
R104 AND R106 IDENTIFIED AS RL IN ASPEN AVIONICS INSTALLATION MANUAL DOCUMENT # 900-00003-001.

CONFIDENTIAL AND PROPRIETARY TO DEKLIN TECHNOLOGIES INC.

DATE:	20-Apr-19	
DRAWN BY	JAD	
CHECKED	JAD	
APPROVED	JAD	www.deklintech.com
PART NO.		TITLE ACU TO CENTURY 1C388/388M/388C/388MC
FILE		SIZE A RE 1 SHEET
		DWG TYPE INTERCONNECT DWG NO

For reference only. Refer to PFD Manufacturers' instructions

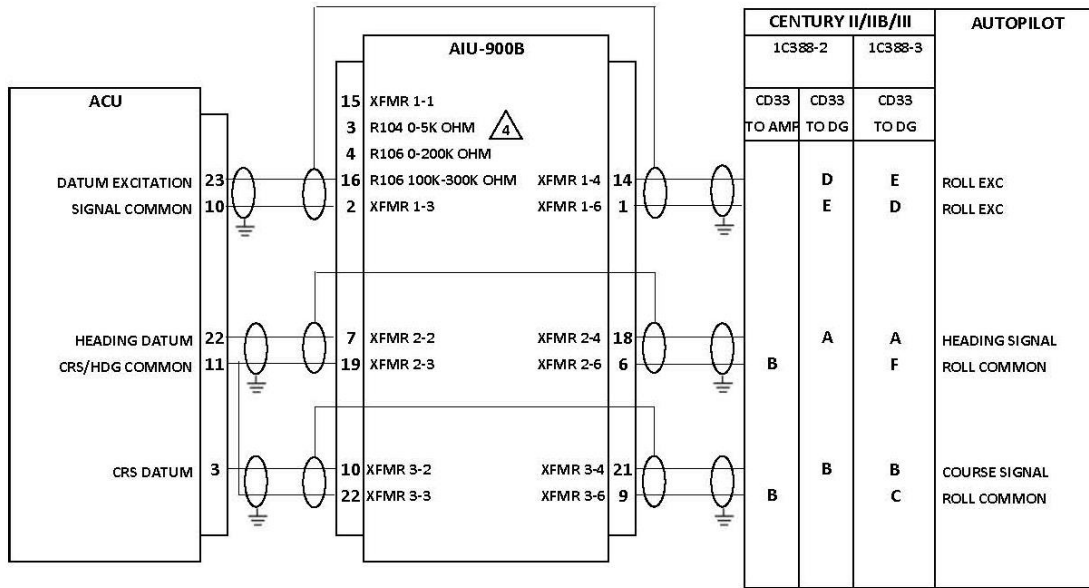

THERE ARE THREE RESISTANCE RANGES AVAILABLE ON THE AIU-900B: R104 (0-5K OHM), R106 (0-200K OHM), AND R106 PLUS 100K OHM RESISTOR (100K-200K OHM). THE OPTIMAL OUTPUT PIN SHOULD BE CHOSEN FOR THE TYPE/MODEL OF THE RADIO COUPLER CONNECTED TO. REFER TO MANUFACTURER'S SPECIFICATIONS. ADDITIONAL EXTERNAL RESISTANCE MAY BE REQUIRED.
R104 AND R106 IDENTIFIED AS RL IN ASPEN AVIONICS INSTALLATION MANUAL DOCUMENT # 900-00003-001

CONFIDENTIAL AND PROPRIETARY TO DEKLIN TECHNOLOGIES INC.

DATE:	20-Apr-19	Deklin Technologies
DRAWN BY	JAD	
CHECKED	JAD	www.deklintech.com
APPROVED	JAD	TITLE ACU TO CENTURY 1C388-2 / 1C388-3
PART NO.		SIZE A RE 1 SHEET
FILE		DWG TYPE INTERCONNECT DWG NO

For reference only. Refer to PFD Manufacturers' instructions

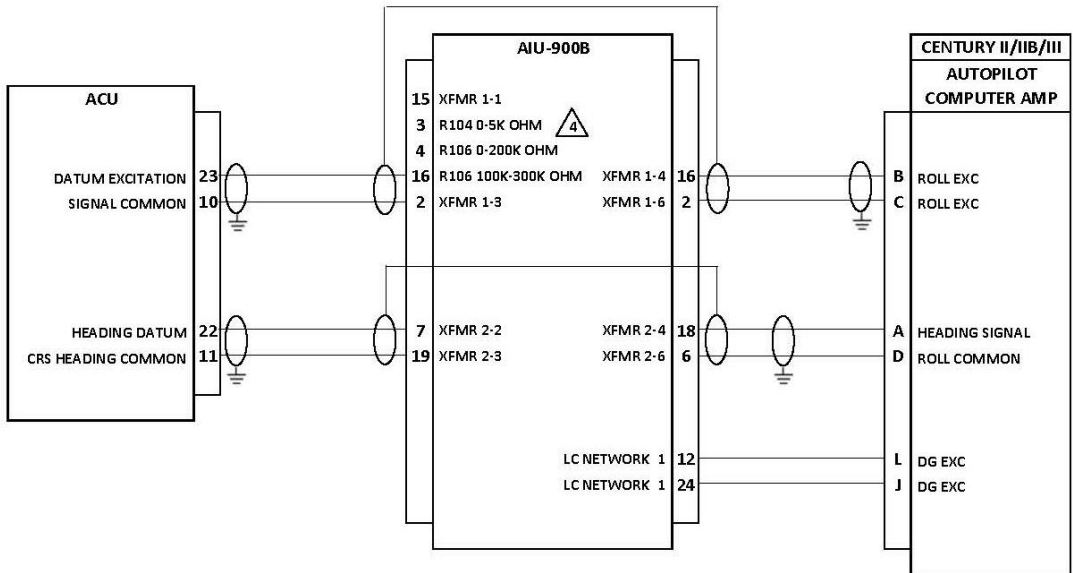

THERE ARE THREE RESISTANCE RANGES AVAILABLE ON THE AIU-900B: R104 (0-5K OHM), R106 (0-200K OHM), AND R106 PLUS 100K OHM RESISTOR (100K-200K OHM). THE OPTIMAL OUTPUT PIN SHOULD BE CHOSEN FOR THE TYPE/MODEL OF THE RADIO COUPLER CONNECTED TO. REFER TO MANUFACTURER'S SPECIFICATIONS. ADDITIONAL EXTERNAL RESISTANCE MAY BE REQUIRED.
R104 AND R106 IDENTIFIED AS R1 IN ASPEN AVIONICS INSTALLATION MANUAL DOCUMENT # 900-00003-001

CONFIDENTIAL AND PROPRIETARY TO DEKLIN TECHNOLOGIES INC.

DATE:	20-Apr-19	 www.deklintech.com			
DRAWN BY	JAD				
CHECKED	JAD				
APPROVED	JAD	TITLE	ACU TO CENTURY NO COUPLER		
PART NO.		SIZE	A	RE' 1	SHEET
FILE		DWG TYPE	INTERCONNECT	DWG NO	

For reference only. Refer to PFD Manufacturers' instructions

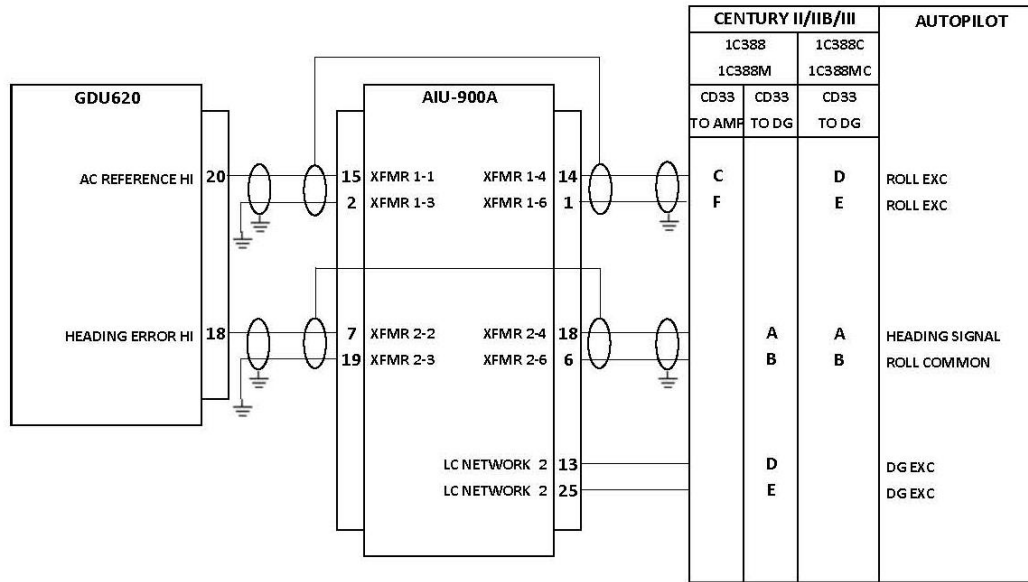

CONFIDENTIAL AND PROPRIETARY TO DEKLIN TECHNOLOGIES INC.

DATE:	20-Apr-19	 Deklin Technologies
DRAWN BY	JAD	
CHECKED	JAD	
APPROVED	JAD	www.deklintech.com
PART NO.		TITLE GDU620 TO CENTURY 1C388/388M/388C/388MC
FILE		SIZE A RE 1 SHEET
		DWG TYPE INTERCONNECT DWG NO

For reference only. Refer to PFD Manufacturers' instructions

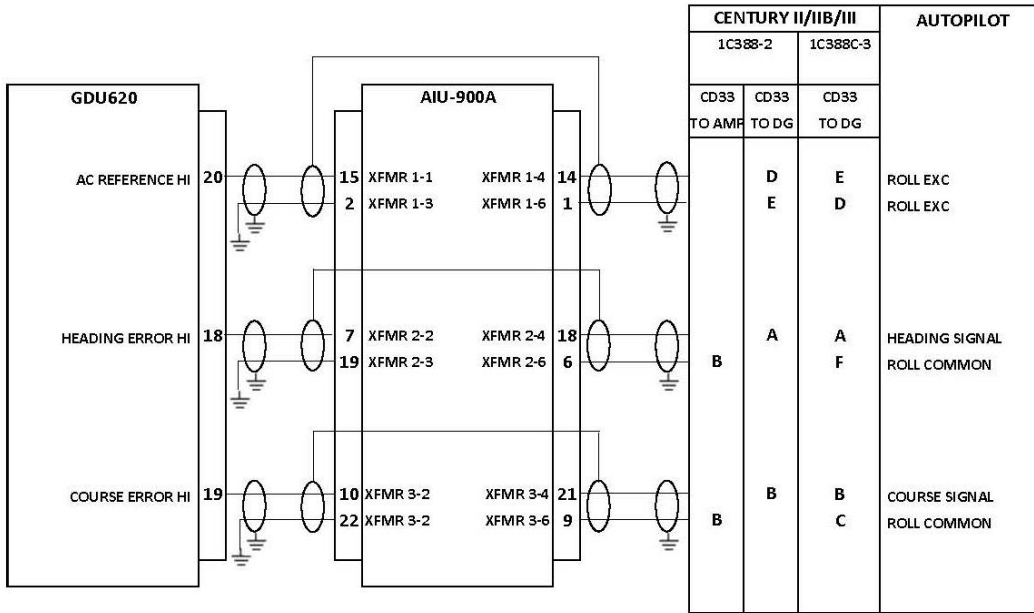

CONFIDENTIAL AND PROPRIETARY TO DEKLIN TECHNOLOGIES INC.

DATE:	20-Apr-19	 Deklin Technologies
DRAWN BY	JAD	
CHECKED	JAD	
APPROVED	JAD	www.deklintech.com
PART NO.		TITLE GDU620 TO CENTURY 1C388-2 / 1C388-3
FILE		SIZE A REV. 1 SHEET
		DWG TYPE INTERCONNECT DWG NO.

For reference only. Refer to PFD Manufacturers' instructions

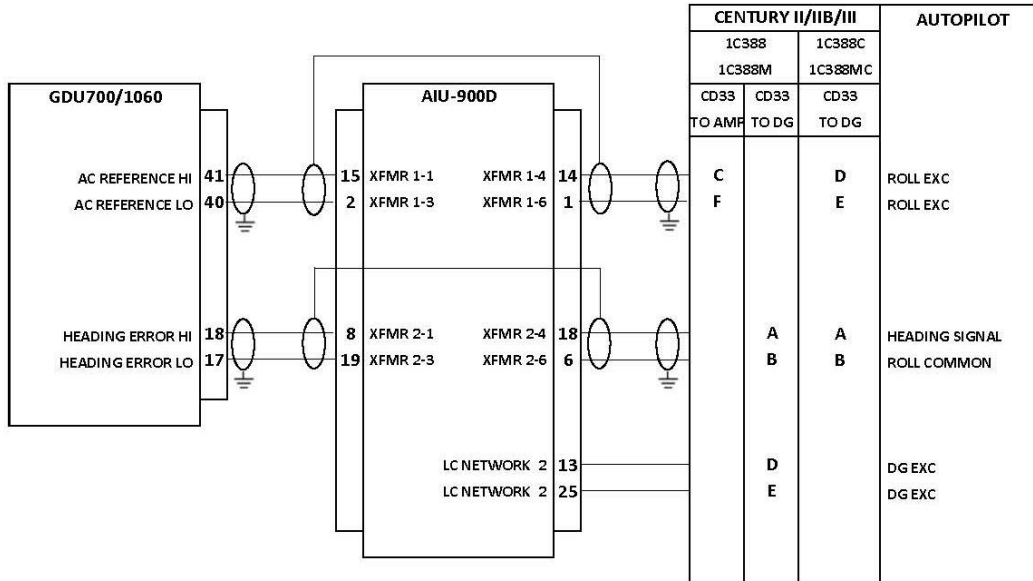

CONFIDENTIAL AND PROPRIETARY TO DEKLIN TECHNOLOGIES INC.

DATE:	20-Apr-19	 www.deklintech.com					
DRAWN BY	JAD						
CHECKED	JAD						
APPROVED	JAD						
PART NO.		TITLE	GDU700/1060 TO CENTURY 1C388/388M/388C/388MC				
FILE		SIZE	A	RE	1	SHEET	
		DWG TYPE	INTERCONNECT		DWG NO		

For reference only. Refer to PFD Manufacturers' instructions

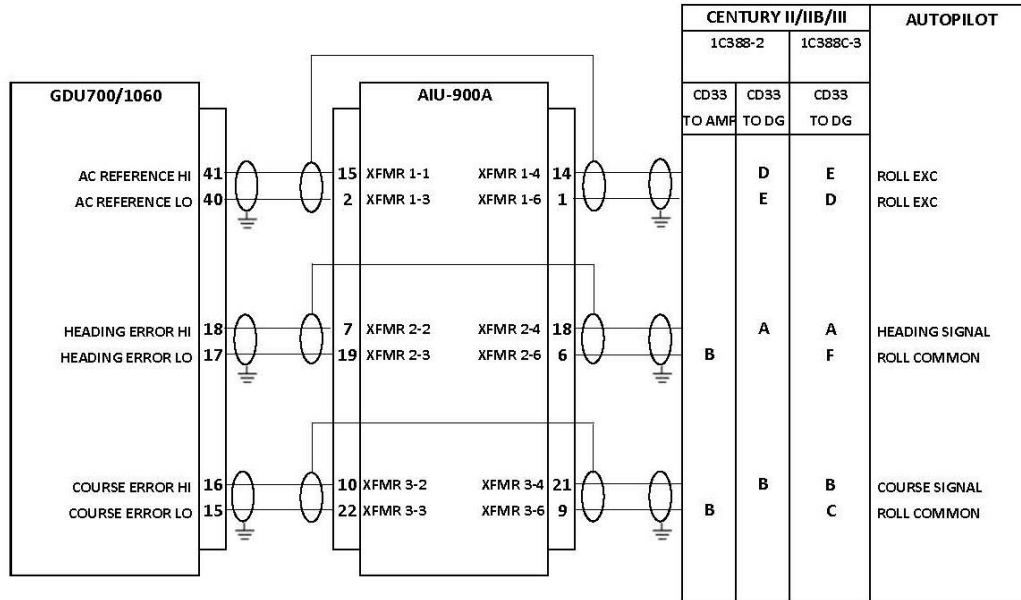

CONFIDENTIAL AND PROPRIETARY TO DEKLIN TECHNOLOGIES INC.

DATE:	20-Apr-19	 Deklin Technologies
DRAWN BY	JAD	
CHECKED	JAD	
APPROVED	JAD	www.deklintech.com
PART NO.		TITLE GDU700/1060 TO CENTURY 1C388-2 / 1C388-3
FILE		SIZE A RE 1 SHEET
		DWG TYPE INTERCONNECT DWG NO

For reference only. Refer to PFD Manufacturers' instructions

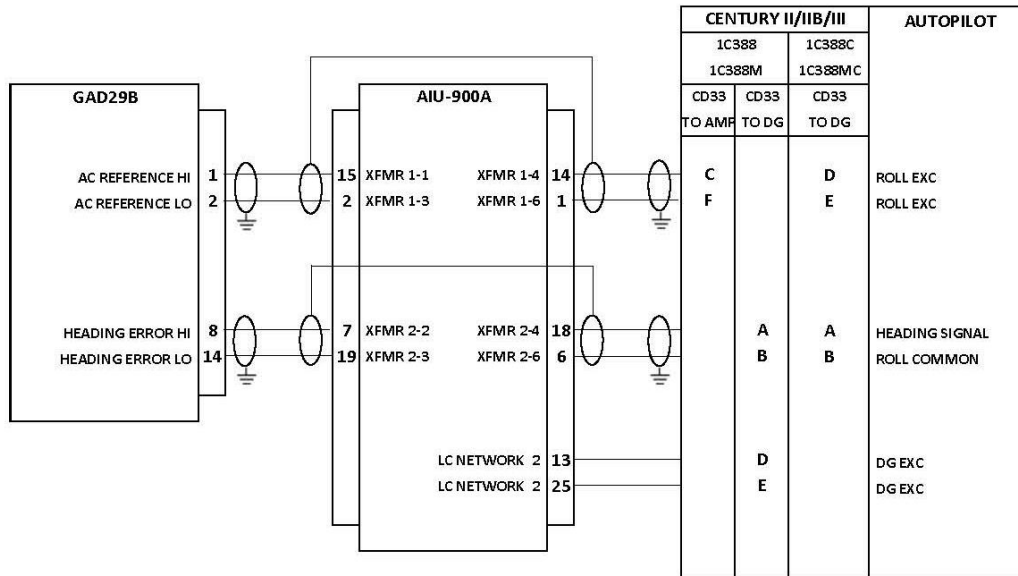

CONFIDENTIAL AND PROPRIETARY TO DEKLIN TECHNOLOGIES INC.

DATE:	20-Apr-19	 Deklin Technologies
DRAWN BY	JAD	
CHECKED	JAD	
APPROVED	JAD	www.deklintech.com
PART NO.		TITLE GAD29B TO CENTURY 1C388/388M/388C/388MC
FILE		SIZE A RE 1 SHEET
		DWG TYPE INTERCONNECT DWG NO

For reference only. Refer to PFD Manufacturers' instructions

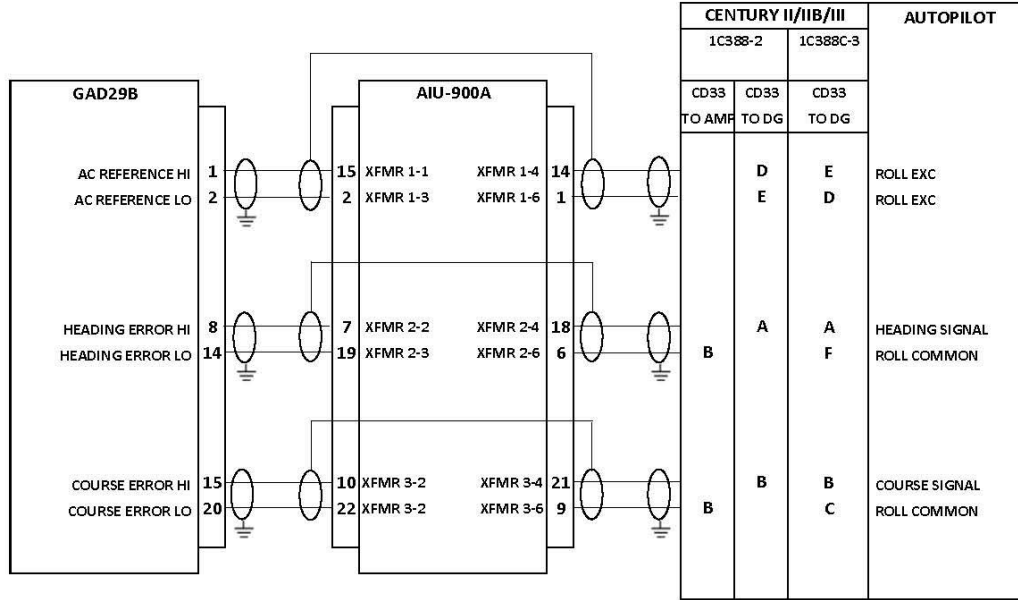

CONFIDENTIAL AND PROPRIETARY TO DEKLIN TECHNOLOGIES INC.

DATE:	20-Apr-19	 Deklin Technologies
DRAWN BY	JAD	
CHECKED	JAD	www.deklintech.com
APPROVED	JAD	TITLE GAD29B TO CENTURY 1C388-2 / 1C388-3
PART NO.		SIZE A RE 1 SHEET
FILE		DWG TYPE INTERCONNECT DWG NO

For reference only. Refer to PFD Manufacturers' instructions

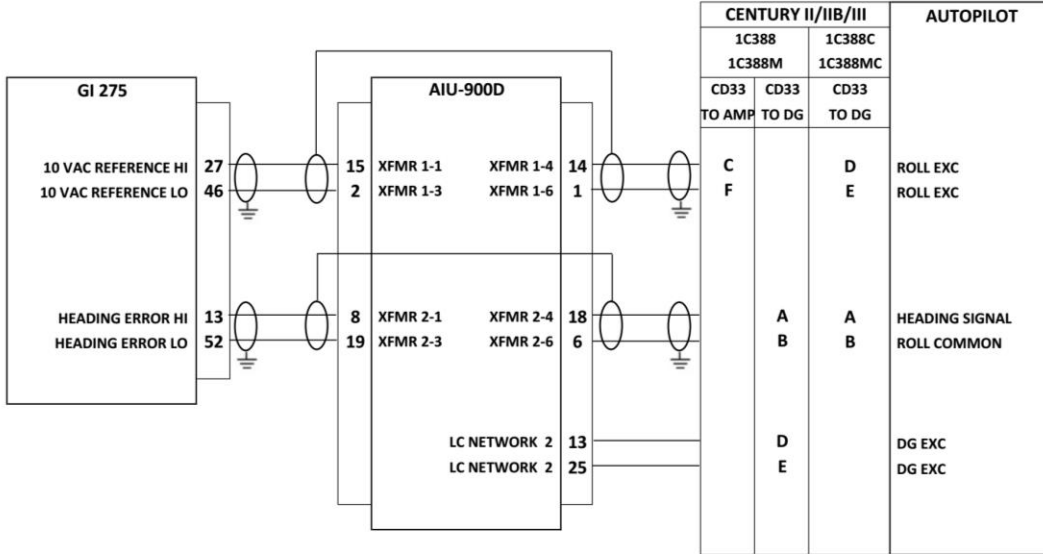

CONFIDENTIAL AND PROPRIETARY TO DEKLIN TECHNOLOGIES INC.

DATE:	10-Jul-20	 Deklin Technologies www.deklintech.com					
DRAWN BY	JAD						
CHECKED	JAD						
APPROVED	JAD						
PART NO.		TITLE	GI275/AIU900D TO 1C388/388M/388C/388MC				
FILE		SIZE	A	REV.	1.0	SHEET	
		DWG TYPE	INTERCONNECT		DWG NO		

For reference only. Refer to PFD Manufacturers' instructions

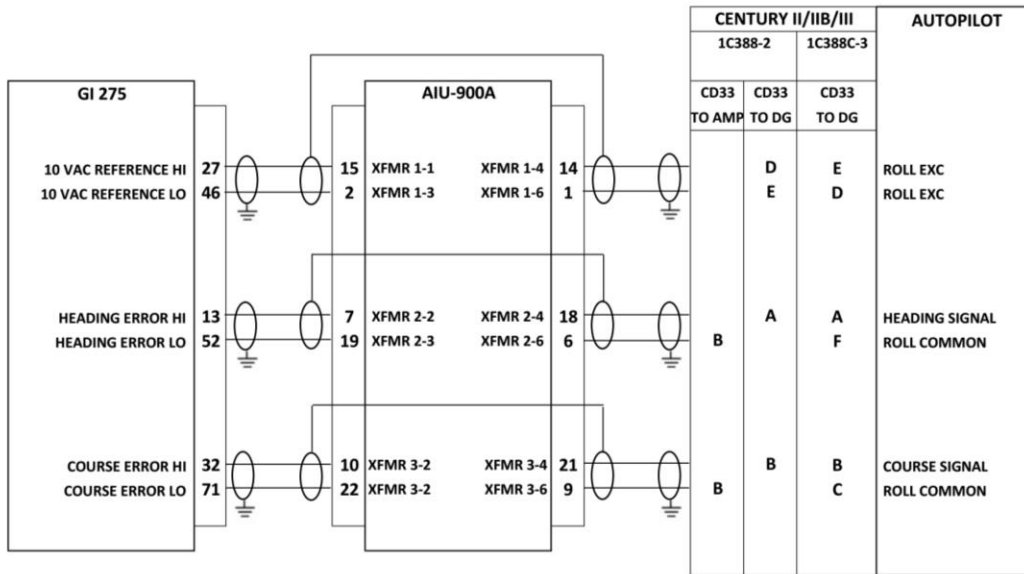

CONFIDENTIAL AND PROPRIETARY TO DEKLIN TECHNOLOGIES INC.

DATE:	10-Jul-20								
DRAWN BY	JAD								
CHECKED	JAD	www.deklintech.com							
APPROVED	JAD								
PART NO.		TITLE	GI 275 TO CENTURY 1C388-2 / 1C388-3	SIZE	A	REV.	1.0	SHEET	
FILE		DWG TYPE	INTERCONNECT	DWG NO					

For reference only. Refer to PFD Manufacturers' instructions

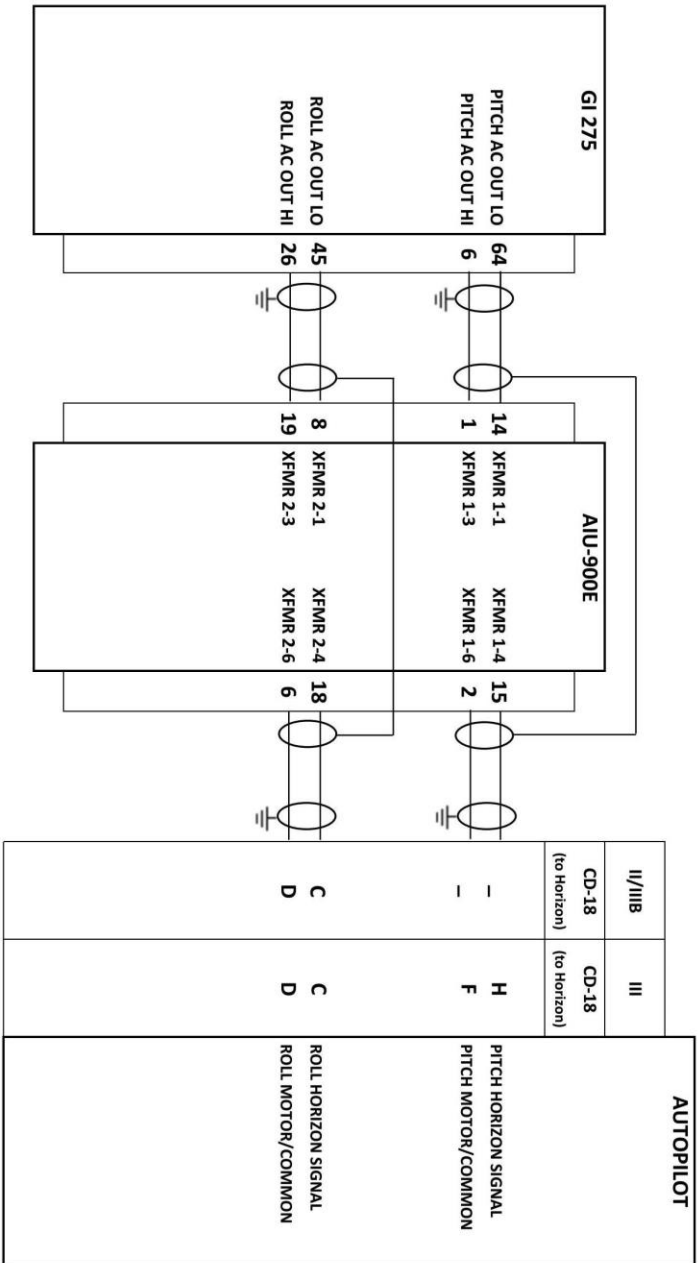

Used with AIU-900D for 1C388, C, M, MC

CONFIDENTIAL AND PROPRIETARY TO DEKLIN TECHNOLOGIES INC.



DATE:	Dec 15/2020	 Deklin Technologies www.deklintech.com		
DRAWN BY	JAD			
CHECKED	JAD	TITLE GI 275 TO CENTURY AP (1C388, C, M, MC)		
APPROVED	JAD			
PART NO.				SIZE A
FILE		DWG TYPE INTERCONNECT	DWG NO.	

For reference only. Refer to PFD Manufacturers' instructions

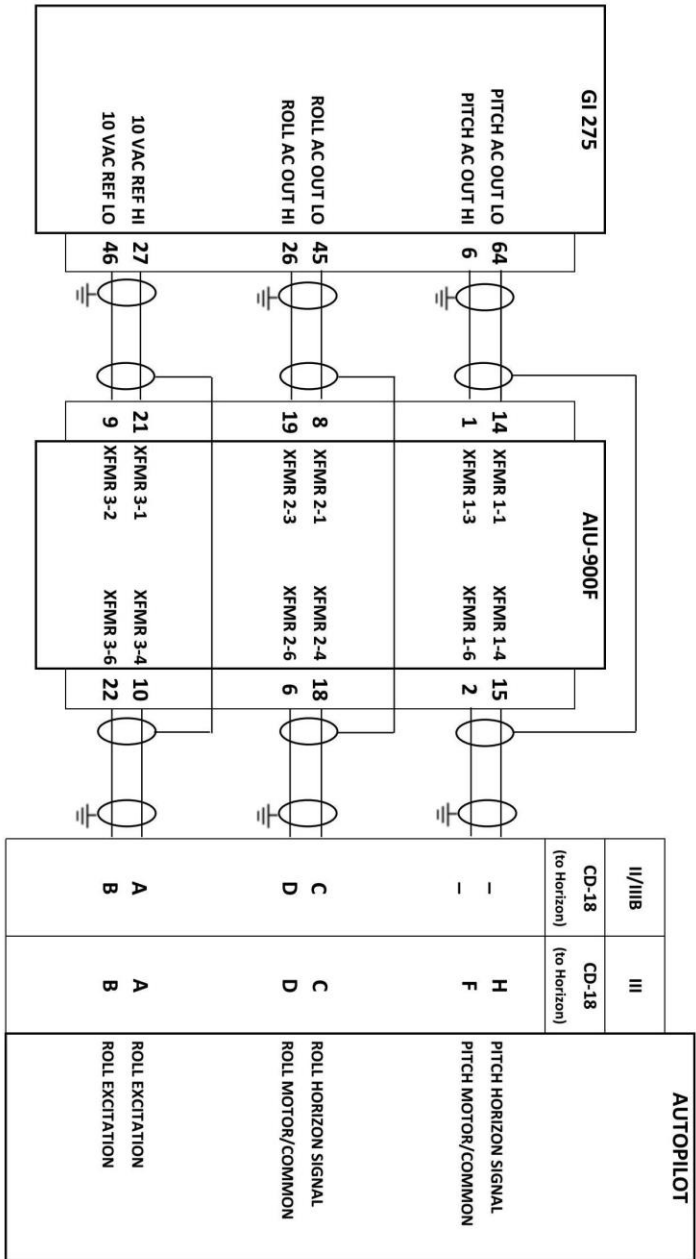

⚠ Used with AIU-900A for 1C388-2 or 1C388-3 Couplers

CONFIDENTIAL AND PROPRIETARY TO DEKLIN TECHNOLOGIES INC.



www.deklintech.com

DATE:	Dec 15/2020						
DRAWN BY	JAD						
CHECKED	JAD	TITLE GI 275 TO CENTURY AP (1C388-2 or 1C388-3)					
APPROVED	JAD						
PART NO.		SIZE	A	REV.	1.0	SHEET	
FILE		DWG TYPE	INTERCONNECT	DWG NO.			

Appendix C - Mechanical

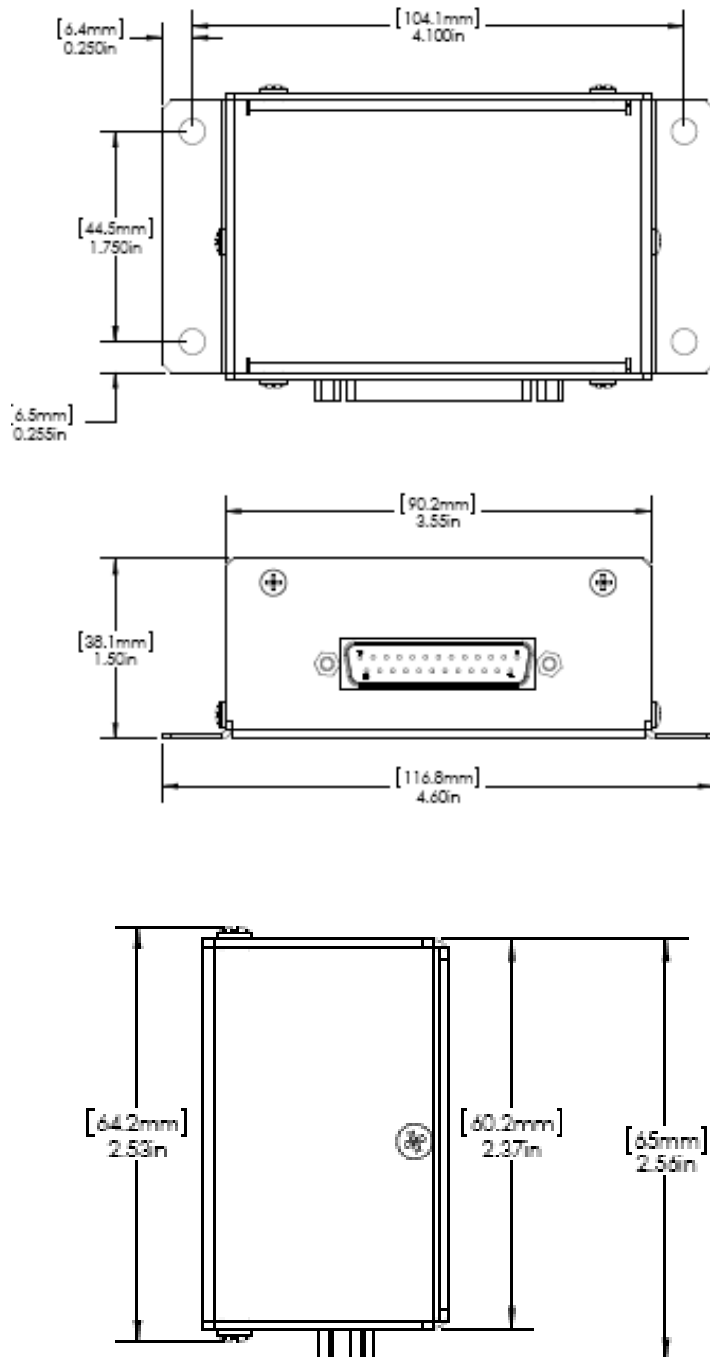

This page left blank



Deklin Technologies