

7270-1 Series Bat Handle Type

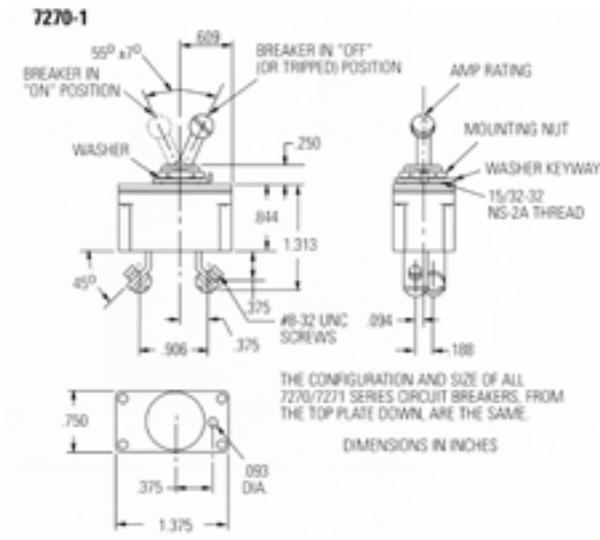

P/N	MS Number
7270-1-3	n/a
7270-1-5	MS24509-A-5
7270-1-7.5	MS24509-A-7.5
7270-1-10	MS24509-A-10
7270-1-15	MS24509-A-15
7270-1-20	n/a
7270-1-25	n/a
7270-1-30	n/a
7270-1-35	n/a

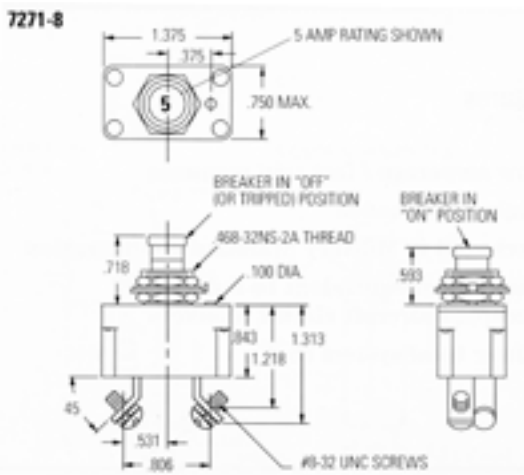

7271-8 Series Push-Pull Type



P/N	MS Number
7271-8-3	n/a
7271-8-5	MS24510-A-5
7271-8-7.5	MS24510-A-7.5
7271-8-10	MS24510-A-10
7271-8-15	MS24510-A-15
7271-8-20	n/a
7271-8-25	n/a
7271-8-30	n/a
7271-8-35	n/a

7274-2 Series Push-Pull Type



P/N	MS Number
7274-2-.5	MS26574-.5
7274-2-.75	MS26574-.75
7274-2-1	MS26574-1
7274-2-1.5	MS26574-1.5
7274-2-2	MS26574-2
7274-2-2.5	MS26574-2.5
7274-2-3	MS26574-3
7274-2-4	MS26574-4
7274-2-5	MS26574-5
7274-2-7.5	MS26574-7.5
7274-2-10	MS26574-10
7274-2-15	N/A
7274-2-20	N/A

7274-2

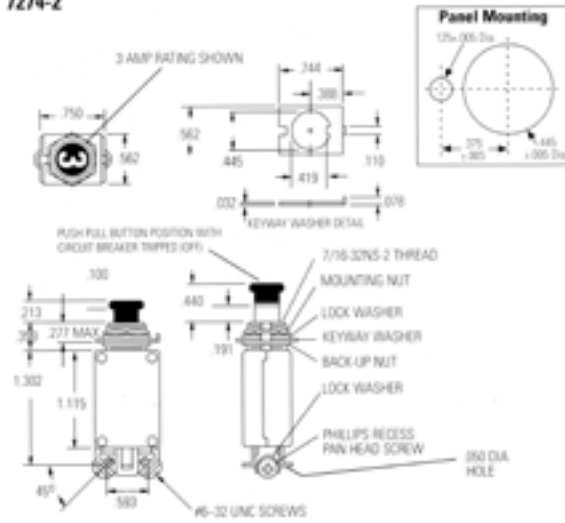

7274-11 Series Push-Pull Type



P/N	MS Number
7274-11-.5	MS22073-.5
7274-11-.75	MS22073-.75
7274-11-1	MS22073-1
7274-11-1.5	MS22073-1.5
7274-11-2	MS22073-2
7274-11-2.5	MS22073-2.5
7274-11-3	MS22073-3
7274-11-4	MS22073-4
7274-11-5	MS22073-5
7274-11-7.5	MS22073-7.5
7274-11-10	MS22073-10
7274-11-15	N/A
7274-11-20	N/A

7274-11

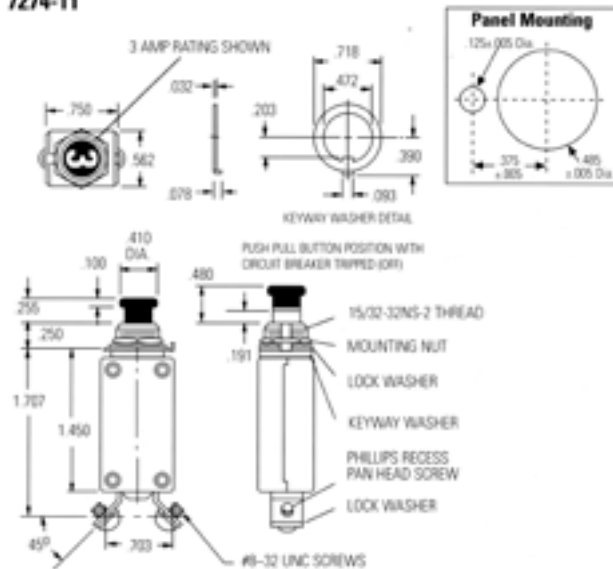

7277-2 Series Push-Pull Type

7277-2

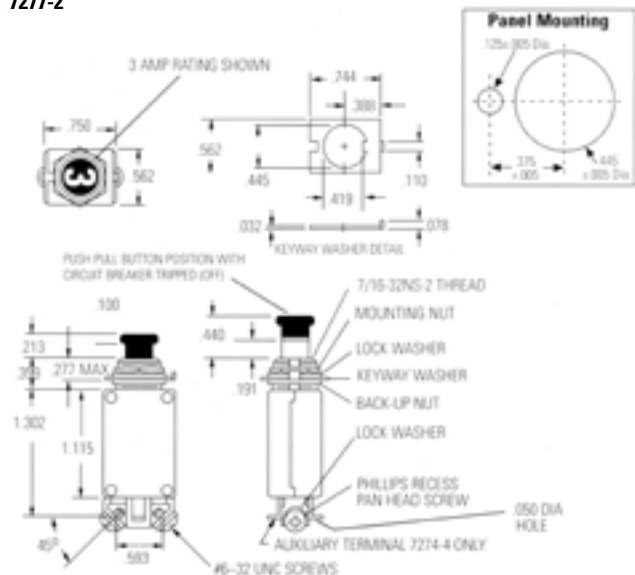

P/N	MS Number
7277-2-5	n/a
7277-2-.75	n/a
7277-2-1	n/a
7277-2-1.5	n/a
7277-2-2	n/a
7277-2-2.5	n/a
7277-2-3	n/a
7277-2-4	n/a
7277-2-5	n/a
7277-2-7.5	n/a
7277-2-10	n/a
7277-2-15	n/a
7277-2-20	n/a

7277-5 Series Push-Pull Type

(Neck is slightly longer than 7277-2)



P/N	MS Number
7277-5-5	n/a
7277-5-.75	n/a
7277-5-1	n/a
7277-5-1.5	n/a
7277-5-2	n/a
7277-5-3	n/a
7277-5-4	n/a
7277-5-5	n/a
7277-5-7.5	n/a
7277-2-10	n/a
7277-2-15	n/a

2TC2 Series Push-Pull Type



2TC2

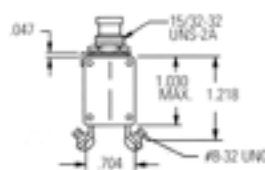
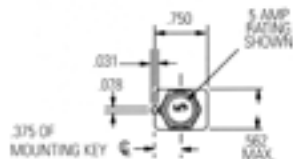
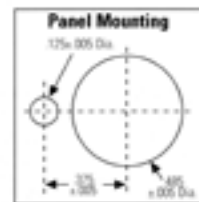

P/N	MS Number
2TC2-1	MS3320-1
2TC2-2	MS3320-2
2TC2-2.5	MS3320-2.5
2TC2-3	MS3320-3
2TC2-4	MS3320-4
2TC2-5	MS3320-5
2TC2-7.5	MS3320-7.5
2TC2-10	MS3320-10
2TC2-15	MS3320-15
2TC2-20	MS3320-20
2TC2-25	N/A

3TC2 Series Push-Pull Type



3TC2
3TC14

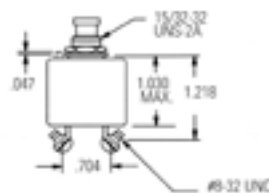
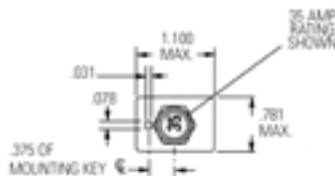
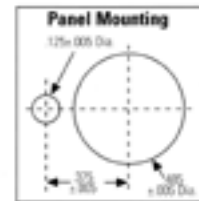

P/N	MS Number
3TC2-15	MS14105-15
3TC2-20	MS14105-20
3TC2-25	MS14105-25
3TC2-30	MS14105-30
3TC2-35	MS14105-35

4200-002 and 4200-005 Series Push-Pull Type

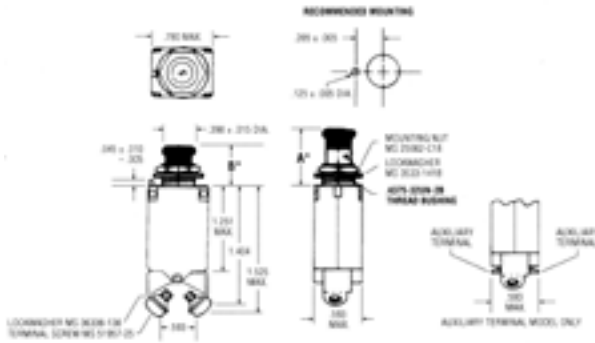

Standard P/N	Long button MS P/N	Amp
4200-002-1	4200-005-1	1
4200-002-2	4200-005-2	2
4200-002-2.5	4200-005-2.5	2.5
4200-002-3	4200-005-3	3
4200-002-4	4200-005-4	4
4200-002-5	4200-005-5	5
4200-002-7.5	4200-005-7.5	7.5
4200-002-10	4200-005-10	10
4200-002-15	4200-005-15	15
4200-002-20	4200-005-20	20
4200-002-25		25



700-001 Series or MS25244 Push-Pull Type

P/N	MS P/N	Amp
700-001-5	MS25244-5	5
700-001-7.5	MS25244-7.5	7.5
700-001-10	MS25244-10	10
700-001-15	MS25244-15	15
700-001-20	MS25244-20	20
700-001-25	MS25244-25	25
700-001-30	MS25244-30	30
700-001-35	MS25244-40	35
700-001-40	N/A	40
700-001-50	N/A	50

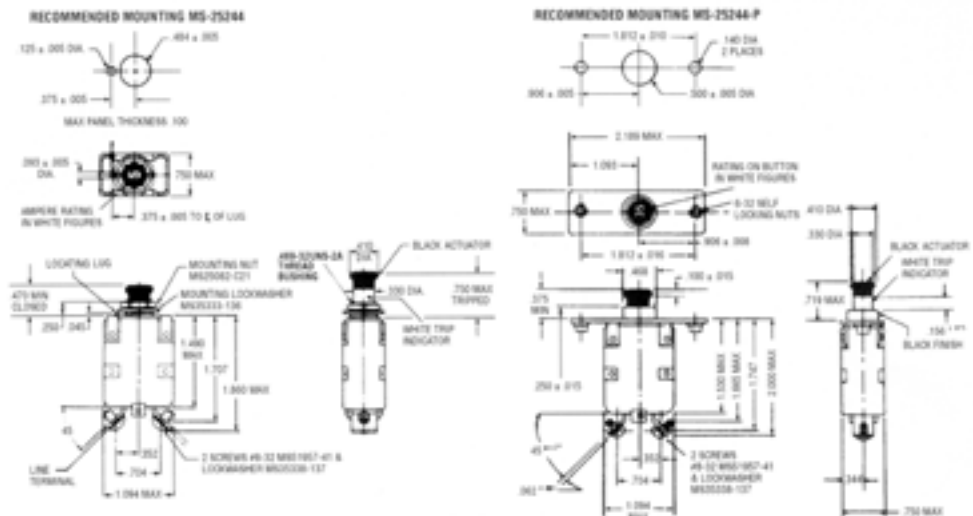

W31X2M1G Series Toggle Type

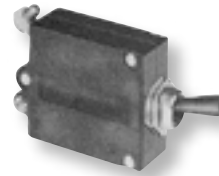
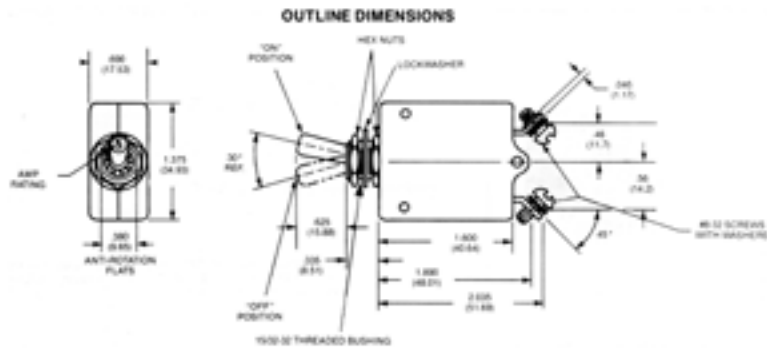

P/N	AMP
W31X2M1G-1	1
W31X2M1G-2	2
W31X2M1G-3	3
W31X2M1G-5	5
W31X2M1G-7.5	7.5
W31X2M1G-10	10
W31X2M1G-15	15
W31X2M1G-20	20
W31X2M1G-25	25
W31X2M1G-30	30
W31X2M1G-35	35
W31X2M1G-40	40
W31X2M1G-50	50

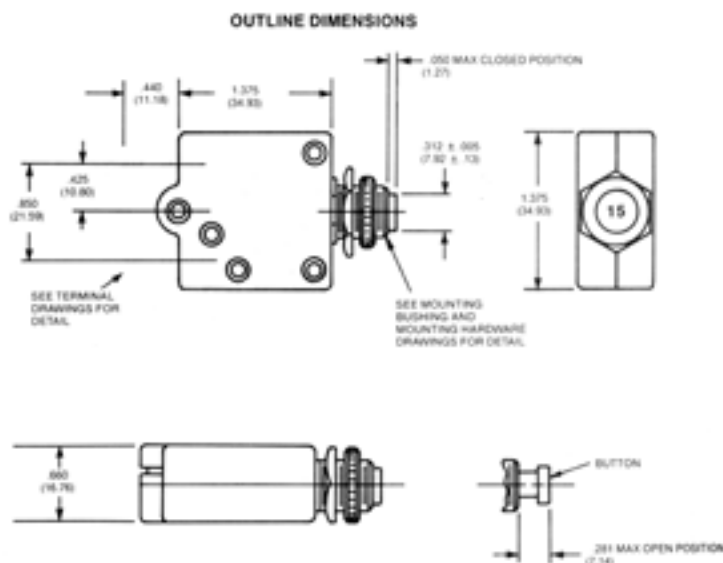
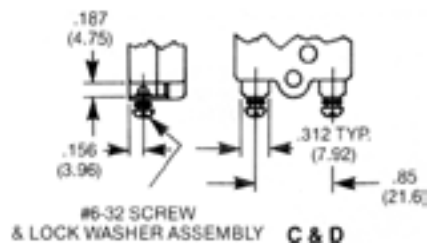

W58XC4C12A Series Recessed-Button Type



P/N	AMP
W58XC4C12A-1	1
W58XC4C12A-2	2
W58XC4C12A-3	3
W58XC4C12A-5	5
W58XC4C12A-6	6
W58XC4C12A-7	7
W58XC4C12A-8	8
W58XC4C12A-10	10
W58XC4C12A-15	15
W58XC4C12A-20	20
W58XC4C12A-25	25
W58XC4C12A-30	30

Breaker Hardware for Klixon and Mechanical Products

P/N	Description
14988-3	Klixon Terminal Screw
11414-4	Klixon 7277 Series Guidewasher
17417-14	Klixon 7277 Series Lockwasher
71212-5	Klixon 7277 Series Mounting Nut
19338-4	Klixon Lockwasher
W23-1	P&B Mounting Nut
W58-1	P&B Mounting Nut
W31-1	P&B Mounting Nut

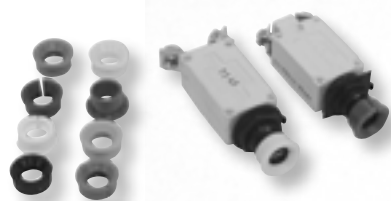

Colored Breaker Collars

These circuit breaker collars facilitate the identification of breakers at just a glance. Greatly improves cockpit management.

P/N	Color
10164-1	Black
10164-2	Ivory
10164-3	White
10164-4	Orange
10164-5	Red
10164-7	Green
10164-8	Gray
10164-9	Yellow
10164-10	Blue



Circuit Breaker Locks

These circuit breaker locks will ensure that circuit breakers will not be closed inadvertently. The lock is extremely useful when equipment has been removed for repair to prevent spikes and shorts.

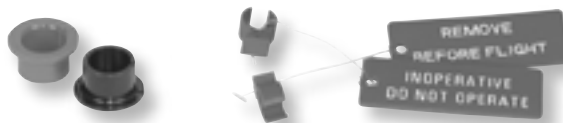

P/N	Color
10237-1	Red
10237-2	Black

P/N	Description
S4933959-501	Red Lock
S4933959-521	Red Lock with tag "REMOVE BEFORE FLIGHT"
S4933959-531	Red Lock with tag "INOPERATIVE DO NOT OPERATE"